

Power Supply Design

Cut Size, Boost Performance

As a power supply designer, you'll understand the continuous pressure to reduce costs, cut size, improve efficiency and create new functionality that differentiates your products from those of competitors. The extensive range of Zetex' discrete and integrated semiconductor devices has been developed to help you achieve these aims. Here's how...

- **World-leading power density:** patented technologies and innovative packaging make Zetex devices amongst the smallest in the world for their power ratings. You save board space, reduce system size and leave room for more functionality to be added when you need it.
- **High efficiency:** the exceptionally high efficiency of Zetex parts means that minimal heat is generated through losses. System cooling arrangements can be made simpler and less expensive. And, because less heat is generated, system reliability is enhanced too (every 10°C rise in temperature halves MTBF).
- **Low noise:** with system operating frequencies rising and operating voltages falling, noise is becoming an ever-greater concern. Every designer is challenged to minimize noise that could affect signal integrity within systems or cause unnecessary interference (EMI/RFI). Zetex devices offer the lowest noise ratings in their class, simplifying the design challenge and contributing towards superior system performance.
- **Economic and reliable:** Zetex devices are designed to be highly competitive whilst making no concessions to quality or subsequent reliability. They are proven in thousands of applications across the world from the most price-sensitive consumer products to the most environmentally demanding automotive systems.

Zetex' portfolio also offers a diverse selection of ICs for audio, video and linear applications as well as motor control and DC-DC conversion, together with a wide discrete component range of MOSFETs and bipolar transistors.

For more information please visit www.zetex.com

Voltage References



Zetex designs and manufactures a range of industry standard shunt voltage regulators. Zetex' focus is to provide excellent performance in small packages, enabling full compatibility in most cases and often the opportunity to reduce power consumption or increase temperature ratings.

The ZRB device operates from a minimum operating current of 50µA with temperature coefficients generally of 90ppm/°C maximum. The ZRC series are advanced capability devices which feature very low minimum operating currents from as low as 20µA. Devices within the ZR series are designed to operate over the temperature range -40 to +85°C.

Features

- Temperature coefficient down to 50ppm/°C
- Minimum (knee) current down to 20µA
- No stabilizing capacitor required
- SOT23 and E-Line packages

Applications

- Optical isolated feedback
- System reference
- Over voltage comparator

For more information, visit www.zetex.com/references

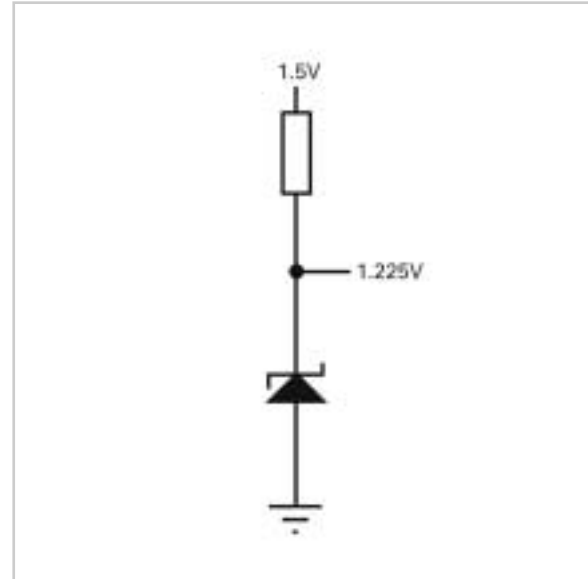

Part Number	Voltage	Tolerance %	Iq mA	I _{max} mA	Tc ppm/°c	Feature
ZXRE4041	1.225	0.5, 1, 2, 3	0.03	12	100	=LM4041
ZRC250	2.500	1, 2, 3	0.02	5	90	Low Iq
ZR431	2.500	0.5, 1, 2	0.05	100	–	Ind std shunt/Low Iq
ZRC330	3.300	1, 2, 3	0.02	5	90	Low Iq
ZRC400	4.096	1, 2, 3	0.02	5	90	Low Iq
ZR4040-41	4.096	1, 2, 3	0.06	15	100	=LM4040-41
ZR4040-50	5.000	1, 2, 3	0.06	15	100	=LM4040-50



Current Monitors

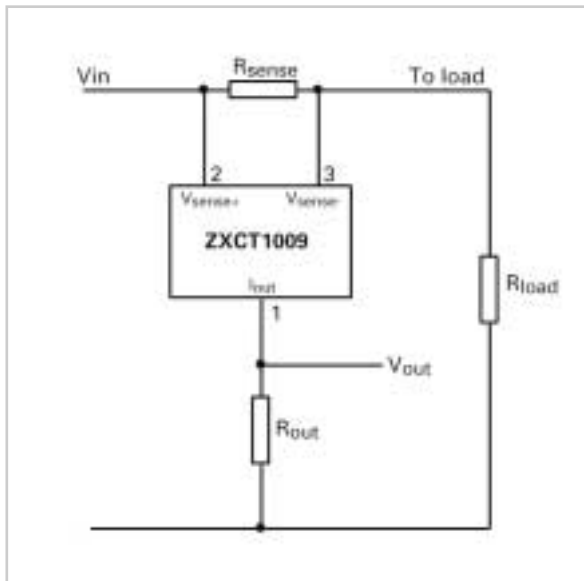

The current monitor range of products from Zetex has been developed to satisfy the widespread need to measure current in electronic circuitry. Current measurement from a few milliamps to tens of amps can be satisfied by these products. Implementation is easy to understand and design solutions quickly reached.

These products are designed to work in the high-side of a circuit and produce a proportional voltage or current at a low-side level, thus facilitating simple interconnection to the control loop electronics. Making high-side measurements avoids the ground disruption required by low-side sensing.

Low quiescent current ensures the minimum overhead in battery powered systems. The ZXCT series has a wide bandwidth, which makes real-time current measurements possible.

Features

- 4 μ A quiescent current
- 2% max accuracy at 100mV V_{sense}
- 1 external resistor for output scaling
- 30ppm/ $^{\circ}$ C output coefficient
- 100ns response time
- Gains of 10 & 100

Applications

- Output current measurement
- Soft start control
- Hot swap surge limiting
- Battery charger

For more information, visit www.zetex.com/zxct

Part Number	Description	V_{IN} (V)	Accuracy @ V_{sense}	Typical Quiescent Current (μ A)	Gain Output/ V_{sense}	Bandwidth (MHz)	Package
ZXCT1009	Simple current monitor	2.5 to 20	+/- 2.5% @ 100mV	5	User defined	2	SOT23, SM8
ZXCT1010	Enhanced offset current monitor	2.5 to 20	+/- 2.5% @ 100mV	3.5	User defined	2	SOT23-5
ZXCT1021	Current monitor for low sense voltage	2.5 to 20	+/- 2% @ 100mV	25	10	1	SOT23-5
ZXCT1022	Current monitor for low sense voltage	2.5 to 20	+/- 3% @ 100mV	25	100	1	SOT23-5
ZXCT1030	Current monitor with internal reference & comparator	2.2 to 20	+/- 3% @ 100mV	270	10	6	MSOP8

MOSFETs



Zetex' wide range of N and P channel MOSFETs extend from 20V to 450V. By deploying high density planar and trench MOSFET technologies we are able to provide tailored devices which are ideal for power supply applications. Our portfolio includes a range of devices that have been optimized to provide low on-resistance, low gate charge and high current handling capability. By providing MOSFETs in a range of surface mount packages, Zetex offers designers the opportunity to reduce size and increase circuit efficiency.

Features

- Very low on-resistance
- Miniature packages
- Ranges of single, dual and H-bridge products
- Good switching performance

Applications

- DC-DC conversion
- Synchronous rectification
- Load switching

For more information, visit www.zetex.com/MOSFET

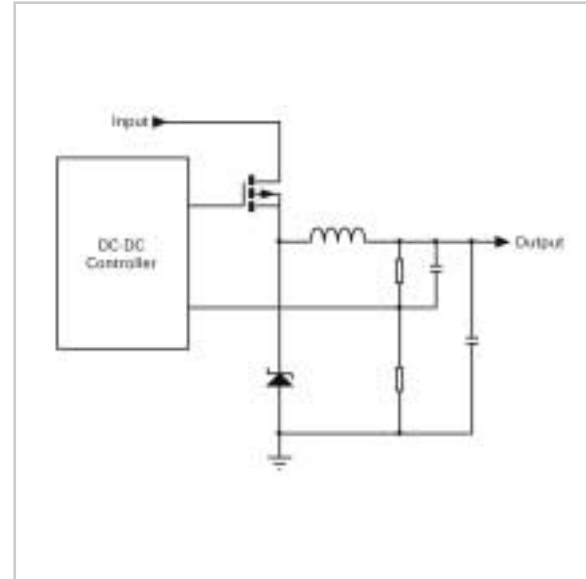

Part Number	BV _{DSS} V	I _D A	P _D W	R _{DS(on)} Max @			C _{ISS} (typ) V _{DS} =0.5BV _{DSS} pF	Q _g (typ) V _{GS} =10V nC	Polarity	Package
				V _{GS} =4.5V Ω	V _{GS} =6V Ω	V _{GS} =10V Ω				
ZXMN3A06DN8	30	6.2	2.1	0.05	-	0.035	750	17.5	2 x N	S08
ZXMP3A17E6	-30	-4	1.7	0.11	-	0.07	630	15.8	P	SOT23-6
ZXMC3AM832	30	3.7	1.5	0.18	-	0.12	190	3.9	N	S08
	-30	-2.7	1.5	0.33	-	0.204	200	5.2	P	
ZXMC6A09DN8	60	5	2.1	0.07	-	0.045	1410	24	P	S08
	-60	-4.6	2.1	0.08	-	0.055	1706	41	N	
ZXMP6A17G	-60	-4.1	3.9	0.19	-	0.125	670	15	P	SOT223
ZXMN6A09DN8	60	5.1	2.1	0.07	-	0.045	1410	24.2	2 x N	S08
ZXMN10A08DN8	100	2.1	1.8	-	0.3	0.25	405	4.2	N	S08
ZXMN10A07Z	100	1.4	1.5	-	0.9	0.7	138	2.9	N	SOT89
ZVN0545G	450	0.14	2	-	-	50	55	-	N	SOT223



Schottky Diodes

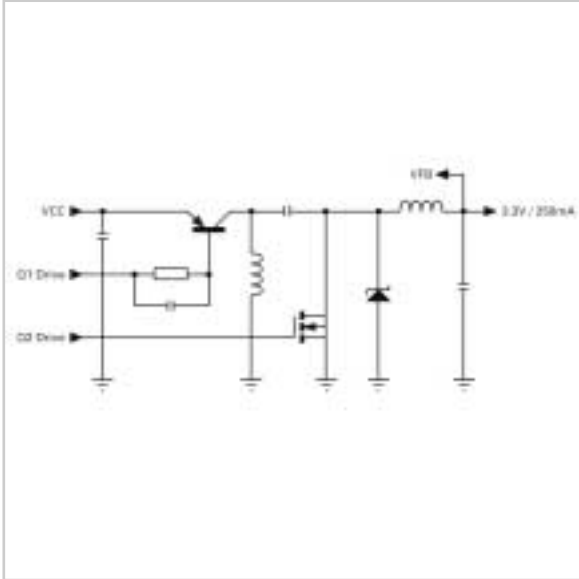

Zetex offers an extensive and expanding range of single die and dual isolated die Schottky rectifier diodes produced by a combination of innovative packaging, improved chip design and processing techniques.

ZHCS series diodes provide excellent high performance specification in miniature surface mount packages. An optimized geometry / process together with superior packaging gives an unmatched I_F/V_F performance and power dissipation capabilities, enabling significant space saving, circuit efficiencies and cost effective solutions.

Complementing the very low V_F performance of the ZHCS series, Zetex' ZLLS range also includes surface mount, high current, very low leakage, fast switching Schottky diodes. These low leakage diodes are ideally suited to applications requiring a battery powered switching regulator with low quiescent currents. They are also suitable for circuits requiring efficient operation at higher temperatures, often a significant limitation of conventional Schottky types.

Features

- Low forward voltage
- High current capability
- Fast recovery time
- Miniature package size

Applications

- Battery powered switching regulator circuit
- Buck, boost and flyback converters
- MOSFET gate protection
- Level shifting

For more information, visit www.zetex.com/schottky

Part Number	V_R	I_F	I_{FSM}	$V_F@$		$I_R@$		Capacitance @ $V_R=25V, f=1MHz$	Package
	Max V	Max mA	Max A	Max mV	I_f mA	Max μA	V_R V	Typ. pF	
	ZHCS2000	40	2000	20	500	2000	300	30	
ZHCS1000	40	1000	12	500	1000	100	30	25	
ZHCS750	40	750	12	490	750	100	30	25	
ZHCS500	40	500	6.75	550	500	40	30	20	
ZHCS400	40	400	6.75	500	400	40	30	20	

Part Number	V_R	I_F	I_{FSM}	$V_F@$		$I_R@$		Capacitance @ $V_R=30V, f=1MHz$	Package
	Max V	Max mA	Max A	Max mV	I_f mA	Max μA	V_R V	Typ. pF	
	ZLLS2000	40	2200	36	540	2000	40	30	
ZLLS1000	40	1160	22	560	1000	20	30	26	
ZLLS500	40	700	13	530	500	10	30	16	
ZLLS400	40	540	12	500	400	10	30	15	

Bipolar Transistors



Zetex offers the highest performance available from surface mount packages including SOT323, SOT23, SOT89 and SOT223 with voltage choices ranging from 10V to 500V. In power supply units Zetex' low voltage devices <60V excel, specifically benefiting the MOSFET gate driving function. Closely specified NPN and PNP types offering high gain at high current operation and inherently fast switching are also available as single or dual die package options in a 1.5 watt rated micro leaded package (MLP). The introduction of the Generation 5 ZX5T2E6 (20V, PNP, SOT23-6) and ZXT5T3Z (40V, PNP, SOT89) has further strengthened Zetex' portfolio.

Features

- Low equivalent on-resistance
- Extremely low saturation voltage (100mV @ 1A)
- h_{FE} specified up to 12A
- $I_C = 4.5A$ continuous collector current
- 3mm x 2mm MLP package

Applications

- MOSFET gate driving
- Buck, boost and flyback converters
- Low noise push pull circuits
- Low loss static switching

For more information, visit www.zetex.com/bipolar

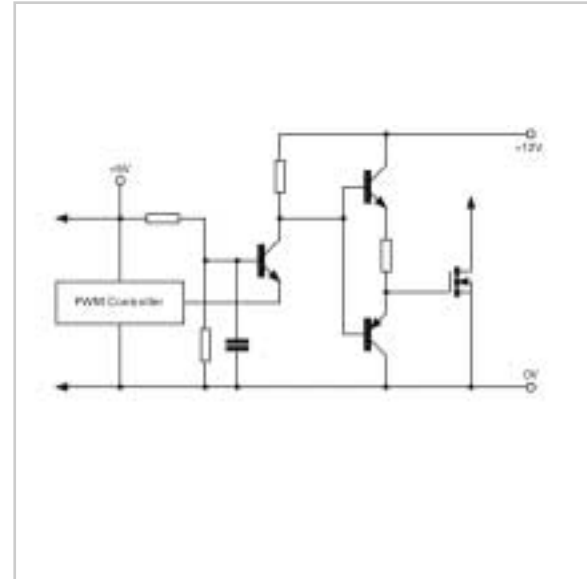

Part Number	Polarity	V _{CEO} V	I _C A	P _D W	h _{FE}		V _{CE(sat)}			R _{CE(sat)} mΩ	Package
					Min	at I _C A	Max V	at I _C A	at I _B mA		
ZXTDA1M832	NPN	15	4.5	1.5	300	0.2	0.1	1	10	45	MLP832
	PNP	-12	-4		300	-0.1	-0.14	-1	-10	60	
ZXTDB2M832	NPN	20	4.5	1.5	300	0.2	0.15	1	10	47	MLP832
	PNP	-20	-3.5		300	-0.1	-0.22	-1	-20	64	
ZXTD4591AM832	NPN	40	2	1.5	300	0.5	0.3	0.5	50	195	MLP832
	PNP	-40	-1.5		250	-0.5	-0.35	-0.5	-20	350	
ZXTDC3M832	NPN	50	4	1.5	300	0.2	0.1	1	50	68	MLP832
	PNP	-40	-3		300	-0.1	-0.22	-1	-50	104	
ZXTDE4M832	NPN	80	3.5	1.5	300	0.2	0.185	1	20	68	MLP832
	PNP	-70	-2.5		300	-0.1	-0.22	-1	-100	117	
ZX5T2E6	PNP	-20	-3.5	1.1	300	-1	-0.14	-1	-10	110	SOT23-6
ZX5T3Z	PNP	-40	-5.5	1.5	200	-0.5	-0.165	-1	-10	29	SOT89



About Zetex

Zetex Semiconductors designs and manufactures high performance semiconductor solutions for analog signal processing and the management of power in automotive, communications, consumer and industrial electronics.

Meeting the demand for greater power economy, precision and speed in analog circuit design, the broad Zetex product range comprises application specific linear ICs and discrete semiconductor devices in multiple package configurations.

As a specialist in analog technology, Zetex offers a diverse series of ICs for audio, video and linear applications as well as motor control and DC-DC conversion. Its discrete component range features trench MOSFETs, IntelliFET™ smart MOSFETs and bipolar transistors.

Headquartered near Manchester in the UK, Zetex Semiconductors has manufacturing and sales operations in Asia, Europe and the USA and is supported by distributors in more than 45 countries.

For more information about Zetex, please visit www.zetex.com

Europe

Zetex GmbH

Streitfeldstraße 19
D-81673 München
Germany
Tel: (49) 89 45 49 49 0
Fax: (49) 89 45 49 49 9
Email: europa.sales@zetex.com

Americas

Zetex Inc

700 Veterans Memorial Highway
Hauppauge, NY 11788
USA
Tel: (1) 631 360 2222
Fax: (1) 631 360 8222
Email: usa.sales@zetex.com

Asia Pacific

Zetex (Asia) Ltd

3701-04 Metroplaza Tower 1
Hing Fong Road, Kwai Fong
Hong Kong
Tel: (852) 26100 611
Fax: (852) 24250 494
Email: asia.sales@zetex.com

Corporate Headquarters

Zetex Semiconductors plc

Lansdowne Road, Chadderton
Oldham, OL9 9TY
United Kingdom
Tel: (44) 161 622 4444
Fax: (44) 161 622 4446
Email: hq@zetex.com

Zetex products are distributed worldwide.
For details, see www.zetex.com/salesnetwork