

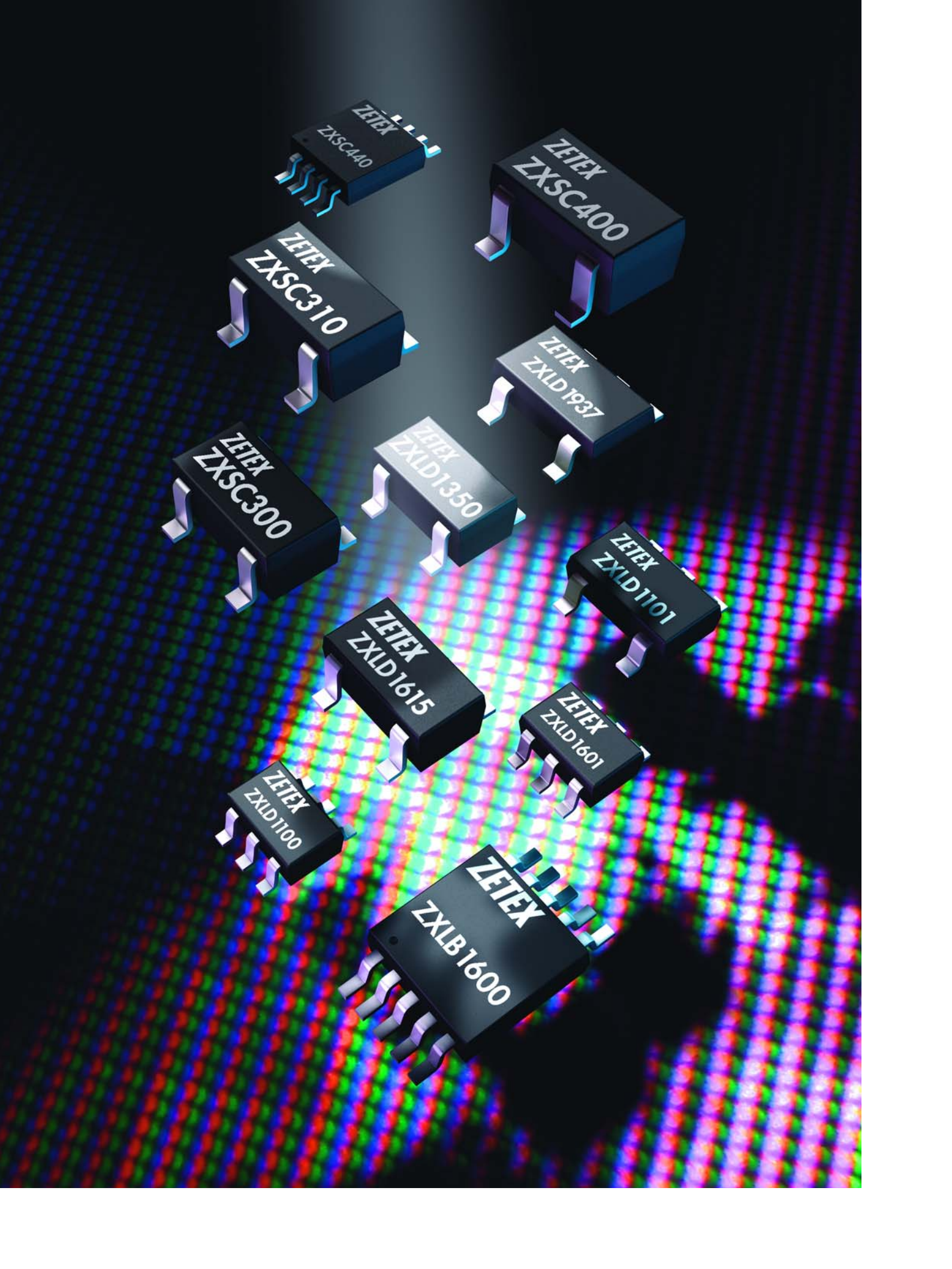

LED driving



High efficiency, cost effective LED driving

More efficient, more rugged and more reliable than alternative incandescent or fluorescent lamps, LEDs provide lighting designers with newfound freedom and flexibility.

Continuous improvements in LED efficiency and colour rendering mean their output performance will challenge that of traditional lighting technologies in many applications.

To ensure the total cost of ownership of LED lighting is comparable with, or even lower than traditional lighting, highly efficient and cost effective methods of driving LEDs is vital.

And that's why Zetex has developed a range of dedicated LED driver ICs to tackle a wide range of existing and emerging applications including:

Display screens

Safety and security lights

Architectural lighting

Camera flash

Automotive lighting

And Zetex LED driver solutions are not only characterized by high efficiency and cost effectiveness. Their incredible versatility means that a simple change in external components can produce the perfect solution for a radically different lighting application. A number are introduced here.

Zetex LED drivers:

Part number	Description	Input voltage range V	Max output voltage range V	Quiescent current μ A	Max. switch current mA	Package
ZXLB1600	LED/OLED boost bias	1.6 - 5.5	28	30	350	MSOP10
ZXLD1100	LED boost driver	2.5 - 5.5	28	60	320	SC70-6
ZXLD1101	LED boost driver	2.5 - 5.5	28	60	320	TSOT23-5
ZXLD1350	350mA LED driver with internal switch	7 - 30	30	15	370	TSOT23-5
ZXLD1360	1A LED driver with internal switch	7 - 30	30	20	1000	TSOT23-5
ZXLD1362*	1A LED driver with internal switch	6 - 60	60	1800	1000	TSOT23-5
ZXLD1575*	x1/x1.5 charge pump 6-channel driver	2.7 - 5.5	5.5	1000 ⁽²⁾	120 ⁽³⁾	QFN1644
ZXLD1601	LCD/OLED boost bias	2.5 - 5.5	28	60	320	SC70-6
ZXLD1615	LCD/OLED boost bias	2.5 - 5.5	28	60	320	TSOT23-5
ZXLD1937	LED boost driver	2.5 - 5.5	28	60	320	TSOT23-5
ZXSC300	LED boost/buck driver	0.8 - 8	Vm	200	External switch	SOT23-5
ZXSC310	LED boost/buck driver	0.8 - 8	Vm	200	External switch	SOT23-5
ZXSC380	Single cell simple boost with integrated switch	0.8 - 6	20	—	80	SOT23
ZXSC400	LED boost driver	1.8 - 8	Vm	150	External switch	SOT23-5
ZXSC440	Photo flash driver	1.8 - 8	Vm	150	External switch	MSOP8

Vm output voltage is determined by the external switch rating

* Advance information

(1) Shutdown mode; output in 'off' state

(2) x1 mode

(3) 30mA/channel

For access to an extensive series of in-depth design and application notes, visit www.zetex.com/leddriving



Display screens

For backlighting small color LCDs, no more than eight white LEDs are needed to ensure a perfectly even light distribution. To drive them, Zetex offers a dedicated range of highly integrated solutions.

The ZXLD1100, 1101 and 1937 are PFM inductive boost converters designed to drive up to six series connected white LEDs from a Li-Ion cell and up to eight from a 5V source. The ICs feature an integrated 350mA rated output switch, able to operate at a maximum of 28V and the ZXLD1100 offers open circuit LED protection too.

With a shutdown current of 0.5µA the converters ensure battery life is maximized and are proven to provide efficiencies up to 85%. Converter output current can be adjusted by applying a PWM control signal to the enable pin and dependent on its frequency, it will produce either a chopped output or a true analog continuous output.

The use of small TSOT23-5 and SC70-6 packaging addresses the space limitations of a broad range of portable applications.

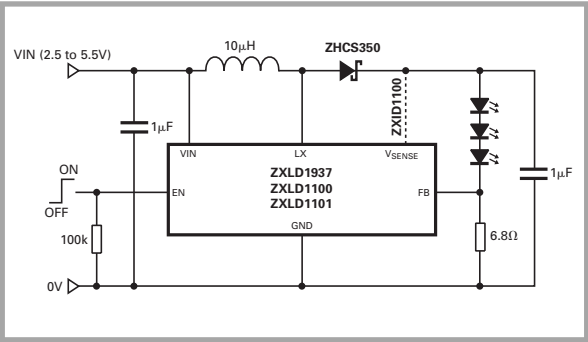

LED driver for backlighting small LCDs



OLED and LCD displays need a bias voltage of between 12V and 32V. In battery powered equipment a voltage boost is required to generate the appropriate voltage and current.

Designed for this application, ZXLD1615, ZXLD1601 and ZXLB1600 are PFM inductive boost converters providing output voltages up to 28V from a 2.5V to 5.5V supply and a typical output current of 10mA at 28V and up to 250mA at 5V. The devices are packaged in space saving TSOT23-5 and SC70-6 formats.

Output voltage is simply set either by two external resistors or by a PWM signal applied to the enable pin. High frequency PWM signals produce a low ripple output, lower frequencies produce a gated output.

To prevent LCD or OLED leakage current draining the battery, the ZXLB1600 includes an input isolation switch to completely disconnect the load during standby.

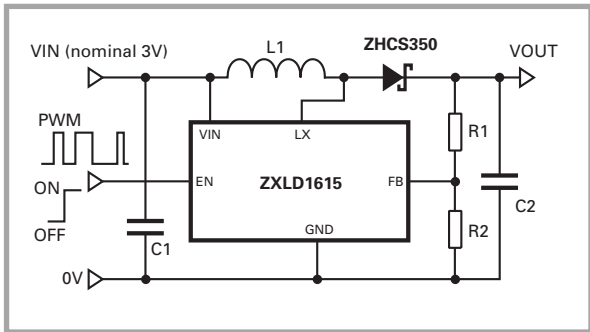

OLED and LCD bias generator

The ZXLD1600 series converters can also generate three voltages for biasing TFT or active matrix displays. A feedback loop controls the AVDD voltage, a voltage doubler generates the VON and a voltage inverter, the VOFF.

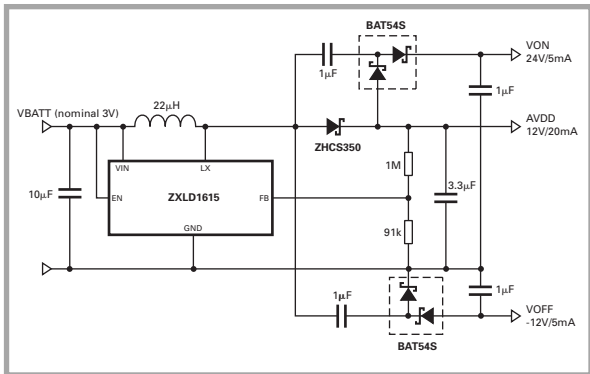

TFT display bias generator

To provide adequate backlighting for large panel LCD screens, far greater numbers of white LEDs are required and the longer strings of LEDs demand far higher switch currents. The ZXSC400 voltage mode boost converter meets the LED driving requirements.

Using external components to manage the larger switch currents and voltages, a ZXSC400 solution can drive a load of up to 30 Watts.

Separate feedback pins allow full control of peak and average LED current and an efficiency of 90% is achieved. Output current can be adjusted by applying a PWM control signal.

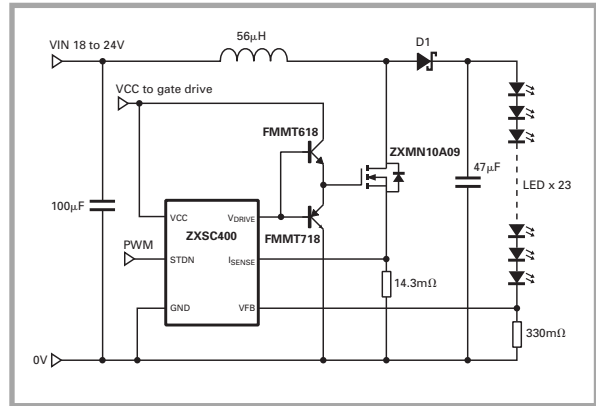

LED driver for backlighting large screens





Safety and security lights

Single cell operation is a significant advantage in hand held equipment, saving space, weight and cost. Specifically designed to drive white LEDs in single cell circuits, the ZXSC300 and ZXSC310 are PFM inductive DC-DC converters that offer simple, highly efficient and elegant design solutions.

The devices can be run in either boost or buck mode, with input and output voltages and currents being determined by the rating of an external transistor. A basic ZXSC310 design platform can support a wide variety of applications by simply changing external components.

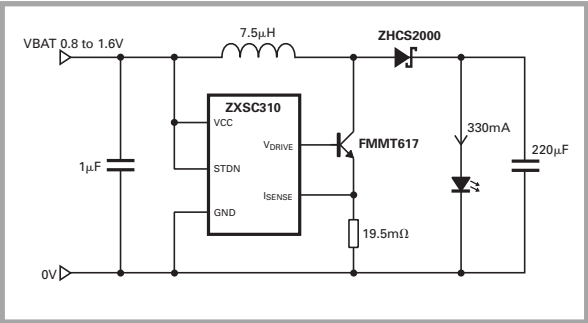

Single cell 1W LED driver



A PFM inductive DC-DC boost converter, the ZXSC400 is designed to drive white LEDs from an input supply of 1.8V to 8V. The converter provides external control over both the peak current and the LED current through the external resistors R1 and R2. This results in good load regulation.

LEDs are also replacing CCFL tubes in emergency lighting applications. As a result, equipment is more reliable, uses fewer batteries and is more rugged. An emergency lighting system using the ZXSC400 PFM inductive DC-DC boost converter requires only two AA cells to drive twelve 30mA white LEDs.

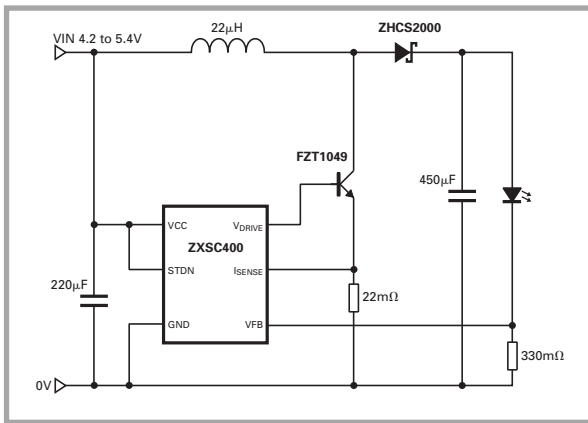

High power driver for 5W LED

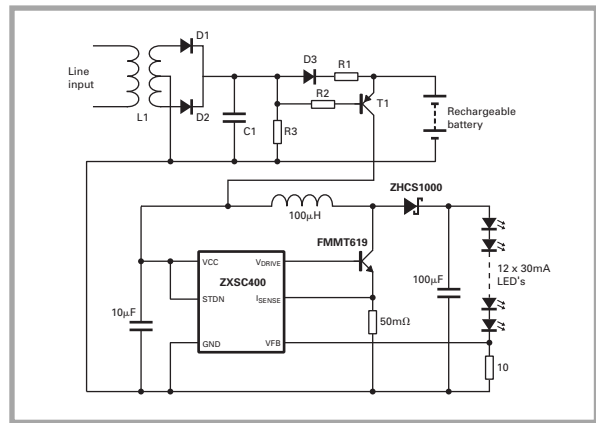

LED based emergency lighting





Architectural lighting

Replacement of line voltage lighting with LEDs is readily achieved using the ZXSC300 PFM inductive DC-DC converter and a suitably rated external transistor switch. The solution can drive 32 white LEDs connected in series and achieves up to 95% efficiency.

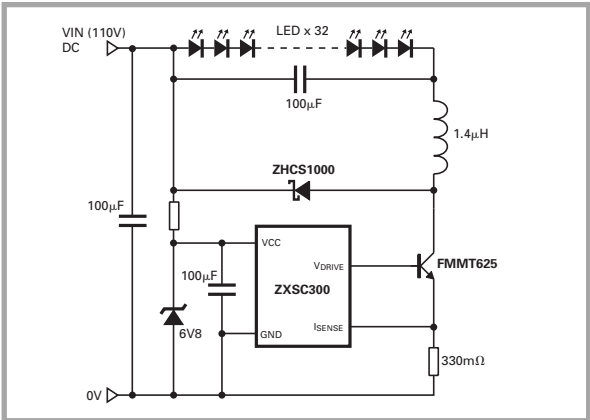

LED light bulb driver



Replacing halogen light bulbs in lighting systems improves efficiency, extends operating life and provides illumination that doesn't generate excessive radiated heat.

Used in buck mode the ZXSC310 PFM inductive DC-DC converter can be used to drive three 1W, high power LEDs. The solution can be used to replace low voltage halogen lamps and achieves up to 95% efficiency.

To increase reliability, maximum LED current needs to be controlled, with respect to temperature. The circuit therefore includes an NTC thermistor. As the temperature rises the LED current is reduced to keep within the safe operating zone. This results in higher brightness, a smaller heat sink and longer life.

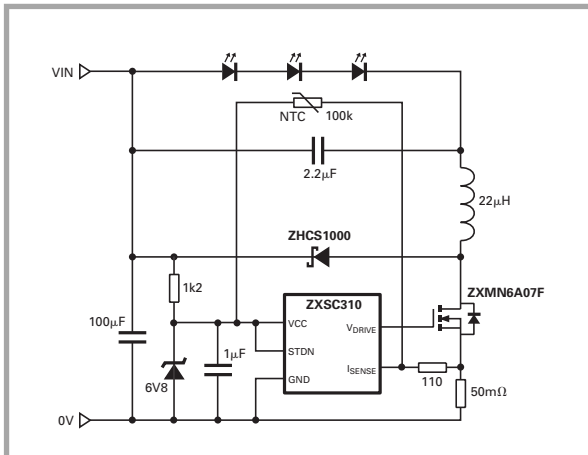

Driver for LED halogen replacement

The ZXLD1350 is a PFM inductive buck converter designed to drive up to three 1W series connected white LEDs from a 12V source. The primary application is 12V halogen replacement and automotive lighting, though a supply voltage range of 7V to 30V makes this part suitable for a wide range of other applications. With a higher supply voltage up to six LEDs can be driven.

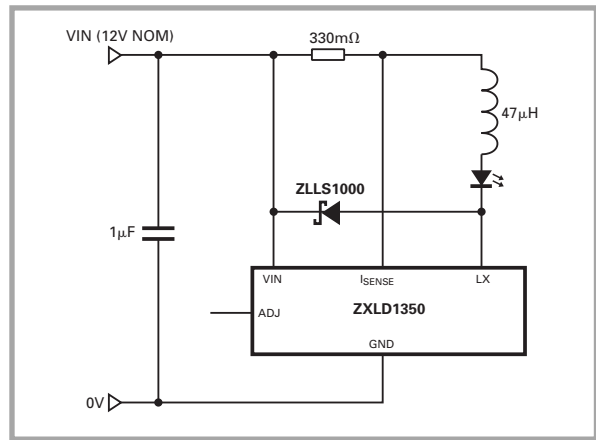

Driver for LED sign lighting





Camera flash

The ZXSC400 voltage mode boost converter provides an ideal solution for an LED based camera flash. Initially the circuit operates as a boost converter to charge C1. In its flash mode the circuit operates as a buck converter to discharge C1 into the LED. The technique avoids high current demand on the battery.

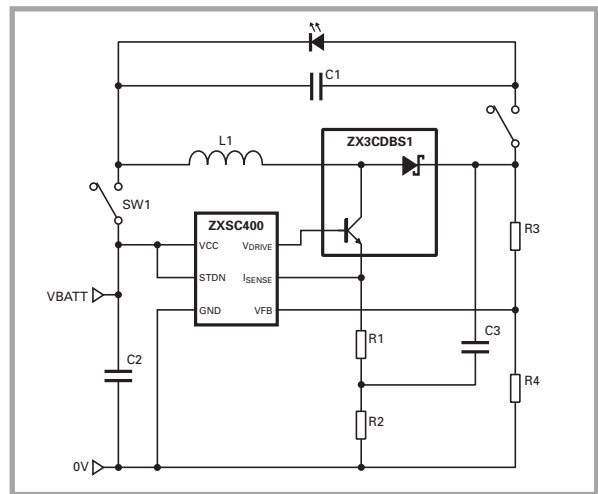

LED camera flash driver

The ZXSC440 is a dedicated Xenon photoflash charger, capable of charging an 80 μ F capacitor to 300V in 3.5 seconds from a 3V supply. The flyback conversion efficiency is typically 75%, much higher than commonly used discrete component charging circuits.

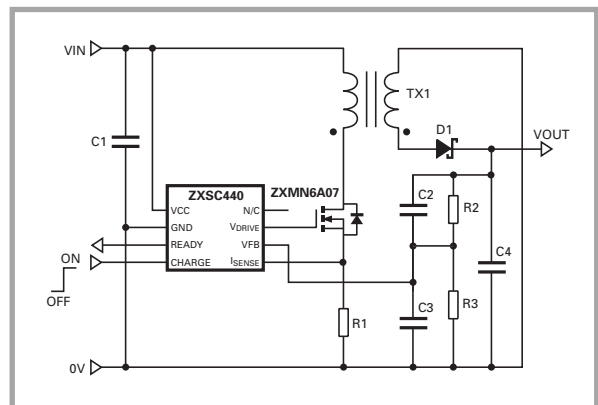

Xenon camera flash charger



Automotive lighting

The automotive industry is beginning to adopt LED technology as a light source in a wide range of applications. LEDs can replace tungsten filament bulbs in the rear lighting cluster, interior LED lighting is already used in some luxury models and will soon migrate to all models. LEDs offer the ability to set the interior mood and style for all classes of automobile. Improved reliability and increased efficiency are attractive to the car manufacturer and owner alike.

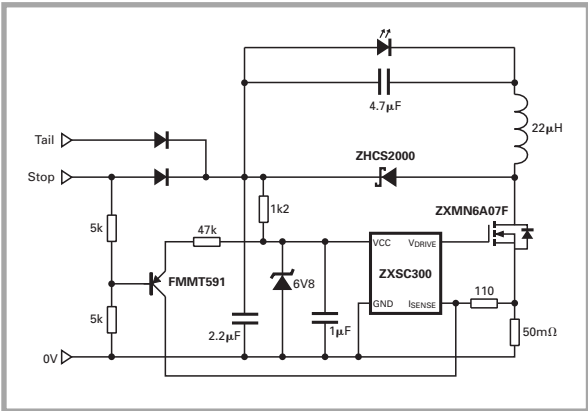

Automotive LED tail light driver





About Zetex

Zetex Semiconductors designs and manufactures high performance semiconductor solutions for analog signal processing and the management of power in automotive, communications, consumer and industrial electronics.

Meeting the demand for greater power economy, precision and speed in analog circuit design, the broad Zetex product range comprises application specific linear ICs and discrete semiconductor devices in multiple package configurations.

As a specialist in analog technology, Zetex offers a diverse series of ICs for audio, video and linear applications as well as motor control and DC-DC conversion. Its discrete component range features trench MOSFETs, IntelliFET™ smart MOSFETs and bipolar transistors.

Headquartered near Manchester in the UK, Zetex Semiconductors has manufacturing and sales operations in Asia, Europe and the USA and is supported by distributors in more than 45 countries.

For more information about Zetex, please visit
www.zetex.com
www.zetex.cn



Zetex Semiconductors is committed to protecting the environment and compliance with all relevant national and international legislation. Zetex products are fully compliant with the European Union's RoHS directive (2002/95/EC). For further information visit www.zetex.com/leadfree

Europe

Zetex GmbH

Kustermann-Park
Balanstraße 59
D-81541 München
Germany
Tel: (49) 89 45 49 49 0
Fax: (49) 89 45 49 49 49
Email: europe.sales@zetex.com

Americas

Zetex Inc

700 Veterans Memorial Highway
Hauppauge, NY 11788
USA
Tel: (1) 631 360 2222
Fax: (1) 631 360 8222
Email: usa.sales@zetex.com

Asia Pacific

Zetex (Asia) Ltd

3701-04 Metroplaza Tower 1
Hing Fong Road, Kwai Fong
Hong Kong
Tel: (852) 2610 0611
Fax: (852) 2425 0494
Email: asia.sales@zetex.com

Corporate Headquarters

Zetex Semiconductors plc

Zetex Technology Park
Chadderton
Oldham, OL9 9LL
United Kingdom
Tel: (44) 161 622 4444
Fax: (44) 161 622 4446
Email: hq@zetex.com

For international sales offices
visit www.zetex.com/offices
Zetex products are distributed worldwide.
For details, see www.zetex.com/salesnetwork