



SPECIFICATION

PART NO. : LMR53DB

5.0mm ROUND LED LAMP



Approved by

Checked by

Prepared by

Yue

Yang

Min Bao

Description

This deep red lamp is made with AlGaInP chip and red diffused epoxy resin.

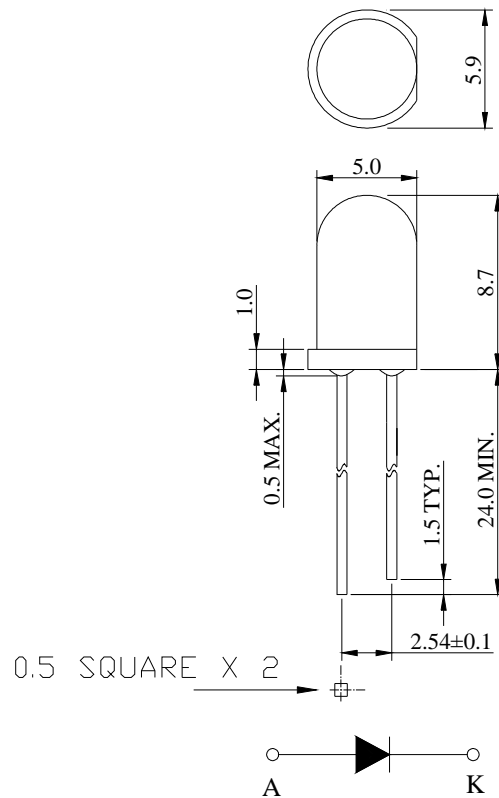

Notes:

1. All dimensions are in mm.
2. The specifications, characteristics and technical data described in the datasheet are subject to change without notice.
3. Tolerance is $\pm 0.25\text{mm}$ unless otherwise noted.

Description

Part No.	LED Chip		Lens Color
	Material	Emitting Color	
LMR53DB	AlGaInP	Deep red	Red diffused



LMR53DB

5.0mm ROUND LED
LAMP

Absolute Maximum Ratings at Ta=25°C

Parameter	Symbol	Rating	Unit
Power Dissipation	P _D	72	mW
Reverse Voltage	V _R	5	V
D.C. Forward Current	I _f	30	mA
Reverse (Leakage) Current	I _r	100	μA
Peak Current(1/10Duty Cycle,0.1ms Pulse Width.)	I _f (Peak)	100	mA
Operating Temperature Range	T _{opr.}	-25 to +85	°C
Storage Temperature Range	T _{stg.}	-40 to +100	°C
Soldering Temperature(1.6mm from body)	T _{sol.}	Dip Soldering : 260°C for 5 sec. Hand Soldering : 350°C for 3 sec.	

Electrical and Optical Characteristics:

Parameter	Symbol	Condition	Min.	Typ.	Max.	Unit
Luminous Intensity	I _v	I _f =20mA	62.2	130		mcd
Forward Voltage	V _f	I _f =20mA		1.9	2.4	V
Peak Wavelength	λ _p	I _f =20mA		660		
Dominant Wavelength	λ _d	I _f =20mA		640		nm
Reverse (Leakage) Current	I _r	V _r =5V			100	μA
Viewing Angle	2θ 1/2	I _f =20mA		35		deg
Spectrum Line Halfwidth	Δλ	I _f =20mA		20		nm

- Notes: 1. Tolerance of Luminous Intensity is ±15%
2. Tolerance of Forward Voltage is ±0.1V
3. Tolerance of Dominant Wavelength is ±1nm
4. Customer's special requirements are also welcome.

Typical Electrical / Optical Characteristics Curves :

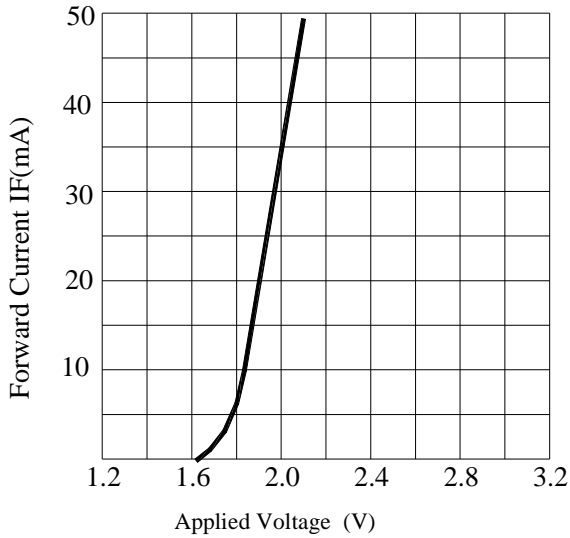

FORWARD CURRENT VS. APPLIED VOLTAGE

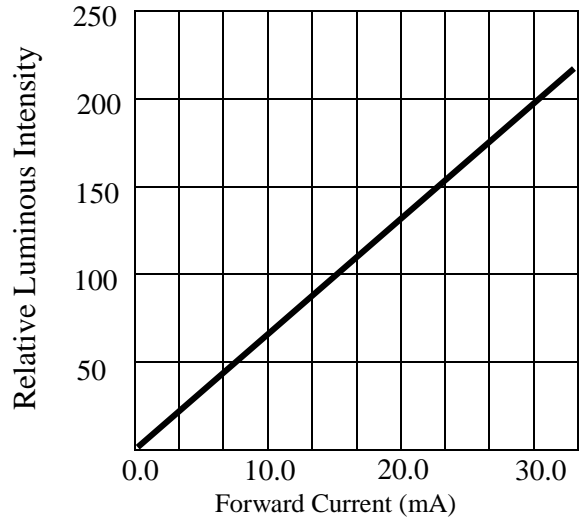

FORWARD CURRENT VS. LUMINOUS INTENSITY

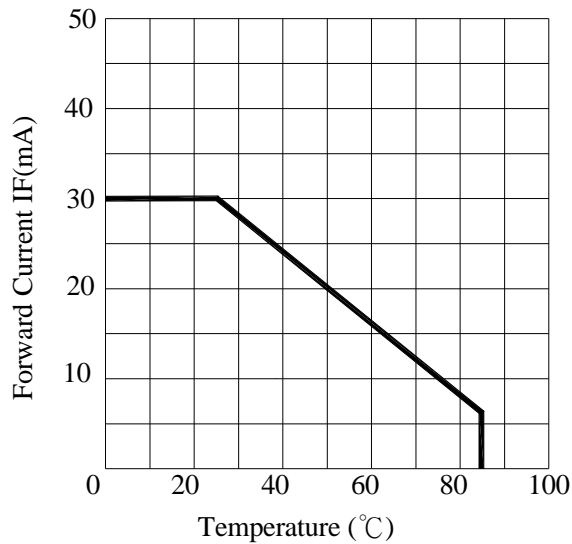

FORWARD CURRENT VS. AMBIENT TEMPERATURE

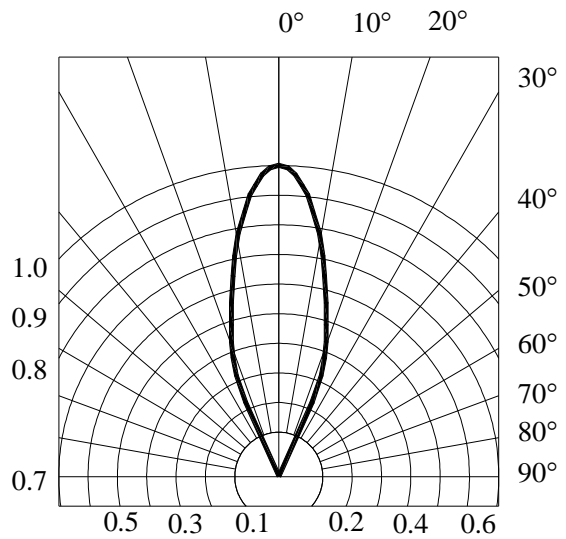

RADIATION DIAGRAM

Precautions:

TAKE NOTE OF THE FOLLOWING IN USE OF LED

1. Temperature in use

Since the light generated inside the LED needs to be emitted to outside efficiently, a resin with high light transparency is used; therefore, additives to improve the heat resistance or moisture resistance (silica gel, etc) which are used for semiconductor products such as transistors cannot be added to the resin. Consequently, the heat resistant ability of the resin used for LED is usually low; therefore, please be careful on the following during use. Avoid applying external force, stress, and excessive vibration to the resins and terminals at high temperature. The glass transition temperature of epoxy resin used for the LED is approximately 120-130°C. At a temperature exceeding this limit, the coefficient of linear expansion of the resin doubles or more compared to that at normal temperature and the resin is softened. If external force or stress is applied at that time, it may cause a wire rupture.

2. Soldering

Please be careful on the following at soldering.

After soldering, avoid applying external force, stress, and excessive vibration until the products go to cooling process (normal temperature), <Same for products with terminal leads>

(1) Soldering measurements:

Distance between melted solder side to bottom of resin shall be 1.6mm or longer.

(2) Dip soldering :

Pre-heat: 90°C max. (Backside of PCB), Within 60 seconds.

Solder bath: 260±5°C (Solder temperature), Within 5 seconds.

(3) Hand soldering: 350°C max. (Temperature of soldering iron tip), Within 3 seconds.

3. Insertion

Pitch of the LED leads and pitch of mounting holes need to be same.

4. Others

Since the heat resistant ability of the LED resin is low, SMD components are used on the same PCB, please mount the LED after adhesive baking process for SMD components. In case adhesive baking is done after LED lamp insertion due to a production process reason, make sure not to apply external force, stress, and excessive vibration to the LED and follow the conditions below.

Baking temperature: 120°C max. Baking time: Within 60 seconds. If soldering is done sequentially after the adhesive baking, please perform the soldering after cooling down the LED to normal temperature.

Disclaimer

1. Our department reserves the right(s) on the adjustment of product material mix for the specification.
2. The product meets our department published specification for a period of twelve (12) months from date of shipment.
3. The graphs shown in this datasheet are representing typical data only and do not show guaranteed values.
4. When using this product, please observe the absolute maximum ratings and the instructions for using outlined in these specification sheets. Our department assumes no responsibility for any damage resulting from the use of the product which does not comply with the absolute maximum ratings and the instructions included in these specification sheets.
5. These specification sheets include materials protected under copyright of our department. Reproduction in any form is prohibited without obtaining our department's prior consent.

This product is not intended to be used for military, aircraft, automotive, medical, life sustaining or life saving applications or any other application which can result in human injury or death. Please contact authorized our department sales agent for special application request.



SPECIFICATION

PART NO. : LMR53WB

5.0mm ROUND LED LAMP



Approved by

Checked by

Prepared by

Yue

Yang

Min Bao

Description

This deep red lamp is made with AlGaInP chip and water clear epoxy resin.

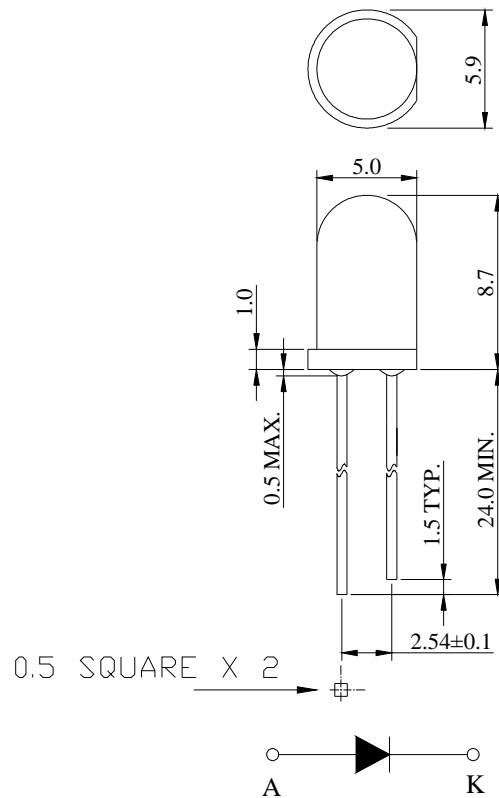

Notes:

1. All dimensions are in mm.
2. The specifications, characteristics and technical data described in the datasheet are subject to change without notice.
3. Tolerance is ± 0.25 mm unless otherwise noted.

Description

Part No.	LED Chip		Lens Color
	Material	Emitting Color	
LMR53WB	AlGaInP	Deep red	Water clear



LMR53WB

5.0mm ROUND LED
LAMP

Absolute Maximum Ratings at Ta=25°C

Parameter	Symbol	Rating	Unit
Power Dissipation	P _D	72	mW
Reverse Voltage	V _R	5	V
D.C. Forward Current	I _f	30	mA
Reverse (Leakage) Current	I _r	100	μA
Peak Current(1/10Duty Cycle,0.1ms Pulse Width.)	I _f (Peak)	100	mA
Operating Temperature Range	T _{opr.}	-25 to +85	°C
Storage Temperature Range	T _{stg.}	-40 to +100	°C
Soldering Temperature(1.6mm from body)	T _{sol.}	Dip Soldering : 260°C for 5 sec. Hand Soldering : 350°C for 3 sec.	

Electrical and Optical Characteristics:

Parameter	Symbol	Condition	Min.	Typ.	Max.	Unit
Luminous Intensity	I _v	I _f =20mA	300	700		mcd
Forward Voltage	V _f	I _f =20mA		1.9	2.4	V
Peak Wavelength	λ _p	I _f =20mA		660		
Dominant Wavelength	λ _d	I _f =20mA		640		nm
Reverse (Leakage) Current	I _r	V _r =5V			100	μA
Viewing Angle	2θ 1/2	I _f =20mA		15		deg
Spectrum Line Halfwidth	Δλ	I _f =20mA		20		nm

- Notes: 1. Tolerance of Luminous Intensity is ±15%
2. Tolerance of Forward Voltage is ±0.1V
3. Tolerance of Dominant Wavelength is ±1nm
4. Customer's special requirements are also welcome.

Typical Electrical / Optical Characteristics Curves :

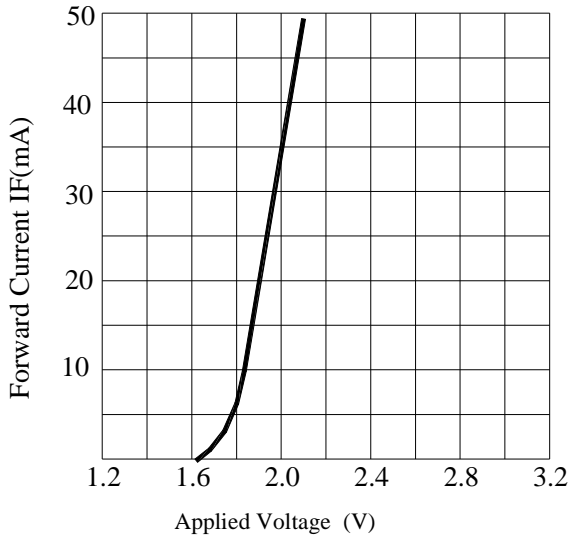

FORWARD CURRENT VS.APPLIED VOLTAGE

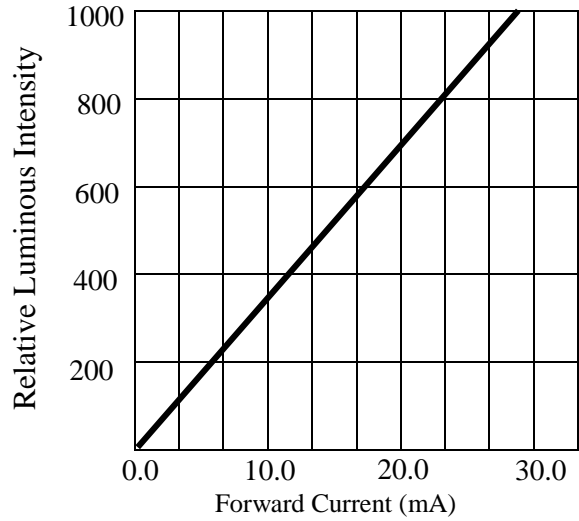

FORWARD CURRENT VS. LUMINOUS INTENSITY

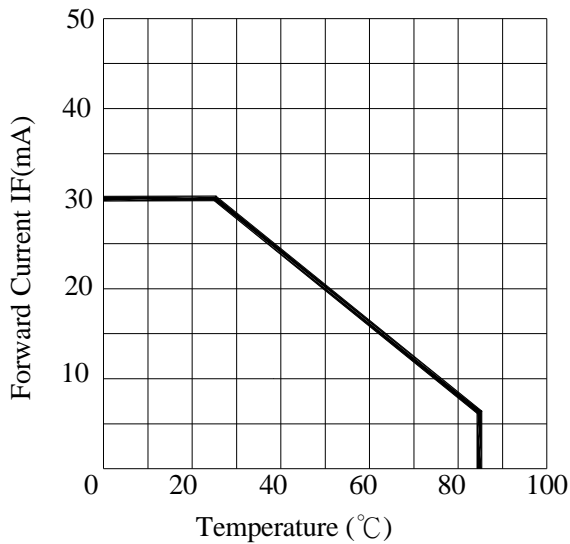

FORWARD CURRENT VS. AMBIENT TEMPERATURE

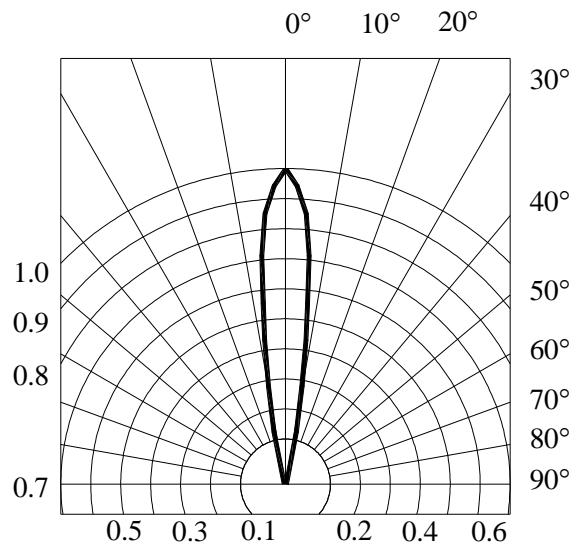

RADIATION DIAGRAM

Precautions:

TAKE NOTE OF THE FOLLOWING IN USE OF LED

1. Temperature in use

Since the light generated inside the LED needs to be emitted to outside efficiently, a resin with high light transparency is used; therefore, additives to improve the heat resistance or moisture resistance (silica gel, etc) which are used for semiconductor products such as transistors cannot be added to the resin. Consequently, the heat resistant ability of the resin used for LED is usually low; therefore, please be careful on the following during use. Avoid applying external force, stress, and excessive vibration to the resins and terminals at high temperature. The glass transition temperature of epoxy resin used for the LED is approximately 120-130°C. At a temperature exceeding this limit, the coefficient of linear expansion of the resin doubles or more compared to that at normal temperature and the resin is softened. If external force or stress is applied at that time, it may cause a wire rupture.

2. Soldering

Please be careful on the following at soldering.

After soldering, avoid applying external force, stress, and excessive vibration until the products go to cooling process (normal temperature), <Same for products with terminal leads>

(1) Soldering measurements:

Distance between melted solder side to bottom of resin shall be 1.6mm or longer.

(2) Dip soldering :

Pre-heat: 90°C max. (Backside of PCB), Within 60 seconds.

Solder bath: 260±5°C (Solder temperature), Within 5 seconds.

(3) Hand soldering: 350°C max. (Temperature of soldering iron tip), Within 3 seconds.

3. Insertion

Pitch of the LED leads and pitch of mounting holes need to be same.

4. Others

Since the heat resistant ability of the LED resin is low, SMD components are used on the same PCB, please mount the LED after adhesive baking process for SMD components. In case adhesive baking is done after LED lamp insertion due to a production process reason, make sure not to apply external force, stress, and excessive vibration to the LED and follow the conditions below.

Baking temperature: 120°C max. Baking time: Within 60 seconds. If soldering is done sequentially after the adhesive baking, please perform the soldering after cooling down the LED to normal temperature.

Disclaimer

1. Our department reserves the right(s) on the adjustment of product material mix for the specification.
2. The product meets our department published specification for a period of twelve (12) months from date of shipment.
3. The graphs shown in this datasheet are representing typical data only and do not show guaranteed values.
4. When using this product, please observe the absolute maximum ratings and the instructions for using outlined in these specification sheets. Our department assumes no responsibility for any damage resulting from the use of the product which does not comply with the absolute maximum ratings and the instructions included in these specification sheets.
5. These specification sheets include materials protected under copyright of our department. Reproduction in any form is prohibited without obtaining our department's prior consent.

This product is not intended to be used for military, aircraft, automotive, medical, life sustaining or life saving applications or any other application which can result in human injury or death. Please contact authorized our department sales agent for special application request.