

Feature of DF57H

The additional guiding keys prevent mis-alignment of mating.

1) There might be a possibility of mis-alignment when mating.

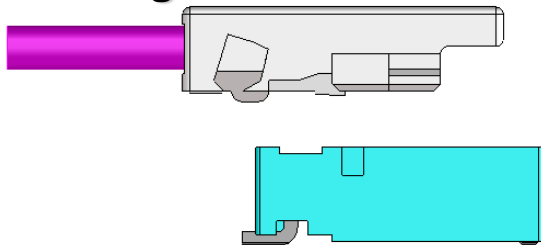

2) The additional guiding keys prevent mis-alignment.

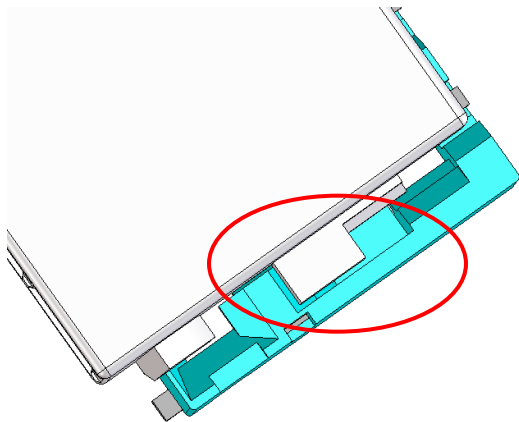

Additional guiding keys

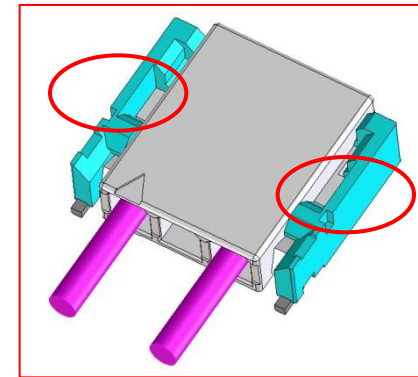

3) The guiding keys touch on the receptacle first to guide the plug correctly.

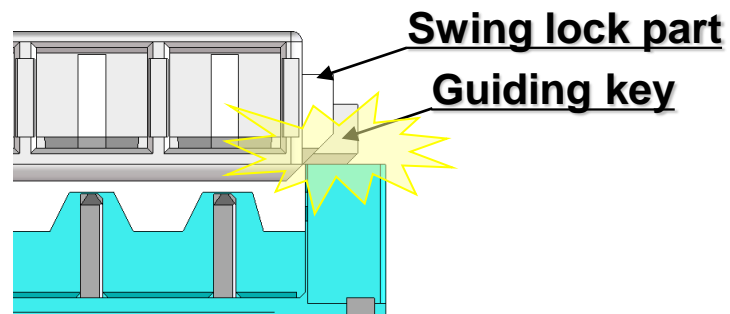

DF57 structures comparison

DF57# - xxP - 1.2V

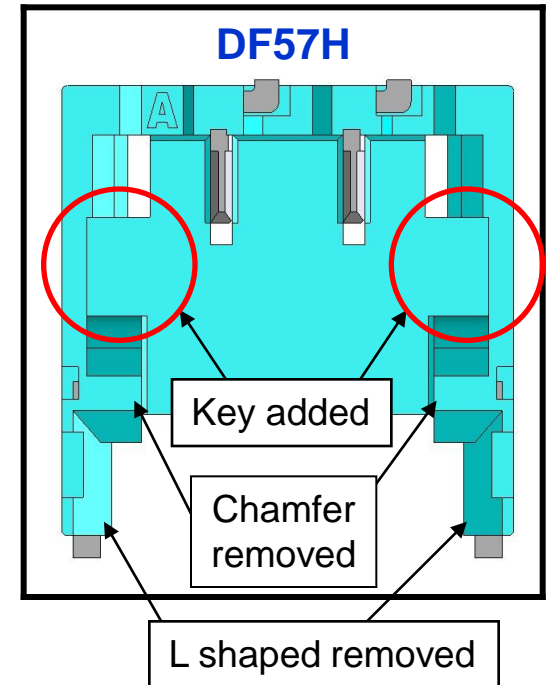
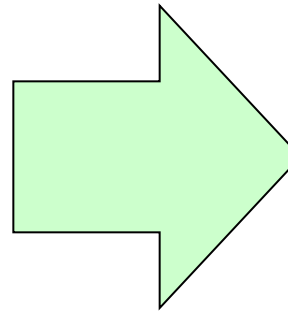
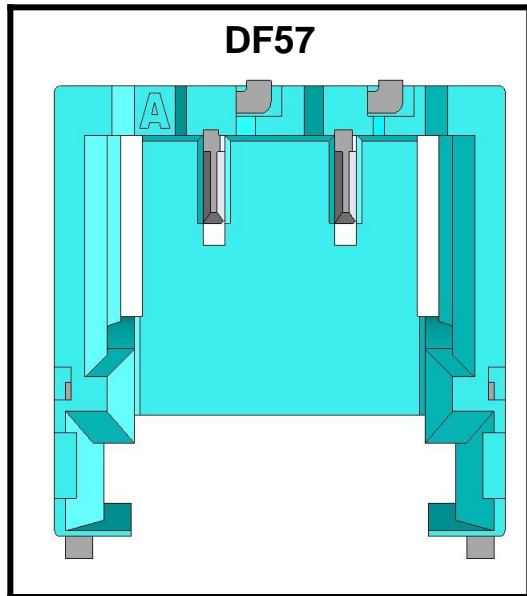

DF57 structures comparison

DF57# - xxS - 1.2C

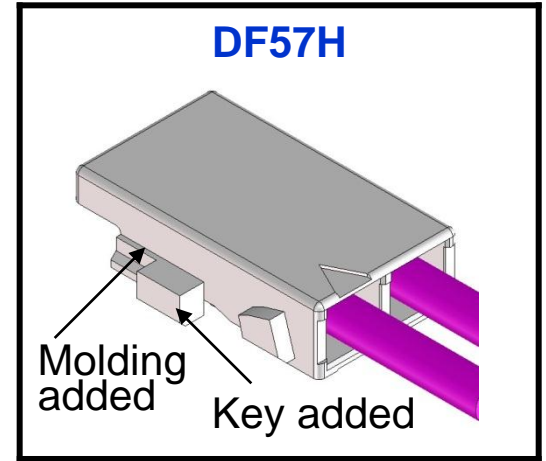
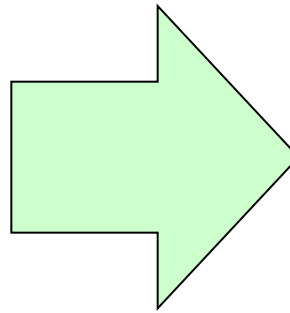
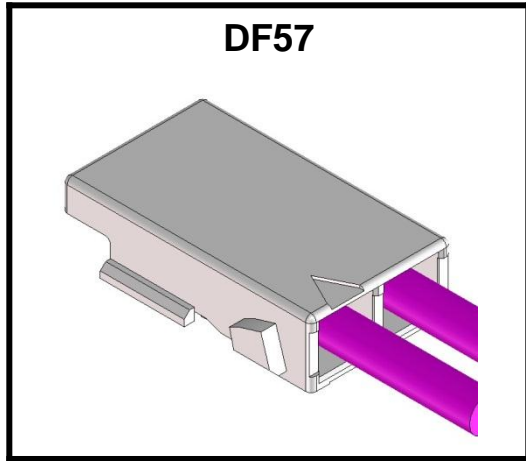

DF57# Mating condition

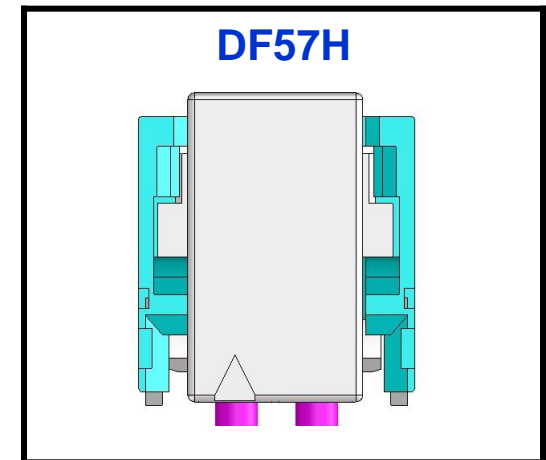
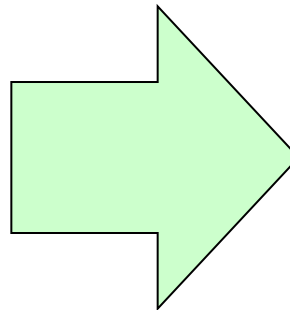
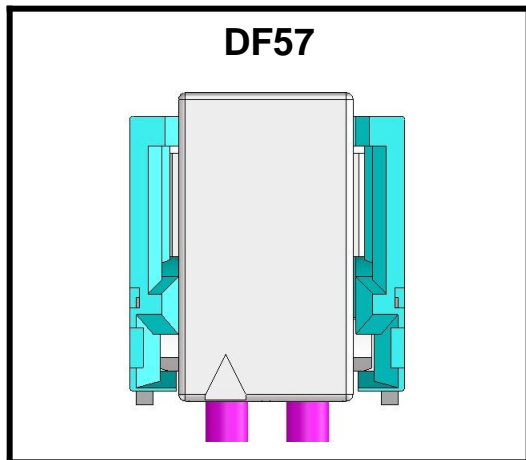

Mating compatibility

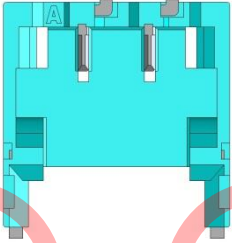
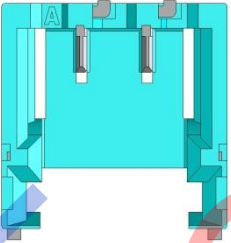
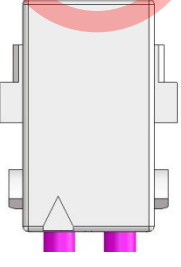
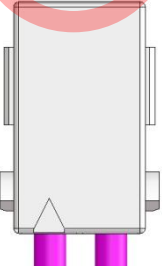
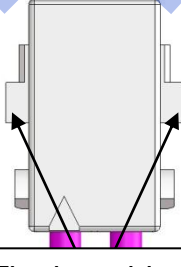
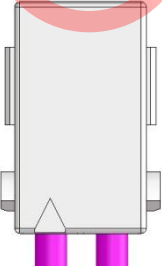
<p>Receptacle</p>	<p>DF57H</p> 		<p>DF57</p> 	
<p>Plug</p>	<p>DF57H</p> 	<p>DF57</p> 	<p>DF57H</p>  <p>The keys block mating</p>	<p>DF57</p> 
<p>Mating compatibility</p>	<p>Y</p>	<p>Y</p>	<p>N</p>	<p>Y</p>
<p>Additional guiding keys</p>	<p>Y</p>	<p>N</p>	<p>-</p>	<p>N</p>