

ECN/PCN No.: M1701

For Manufacturer

Product Description: Series-Connected Supercapacitor Module, 6.0V	Abracon Part Number / Part Series: ADCM-S06R0S	<input type="checkbox"/> Documentation only <input checked="" type="checkbox"/> ECN <input type="checkbox"/> EOL	<input type="checkbox"/> Series <input checked="" type="checkbox"/> Part Number(s)
Affected Revision: B	New Revision: C	Application: <input type="checkbox"/> Safety <input checked="" type="checkbox"/> Non-Safety	

Prior to Change:

Mechanical Specifications

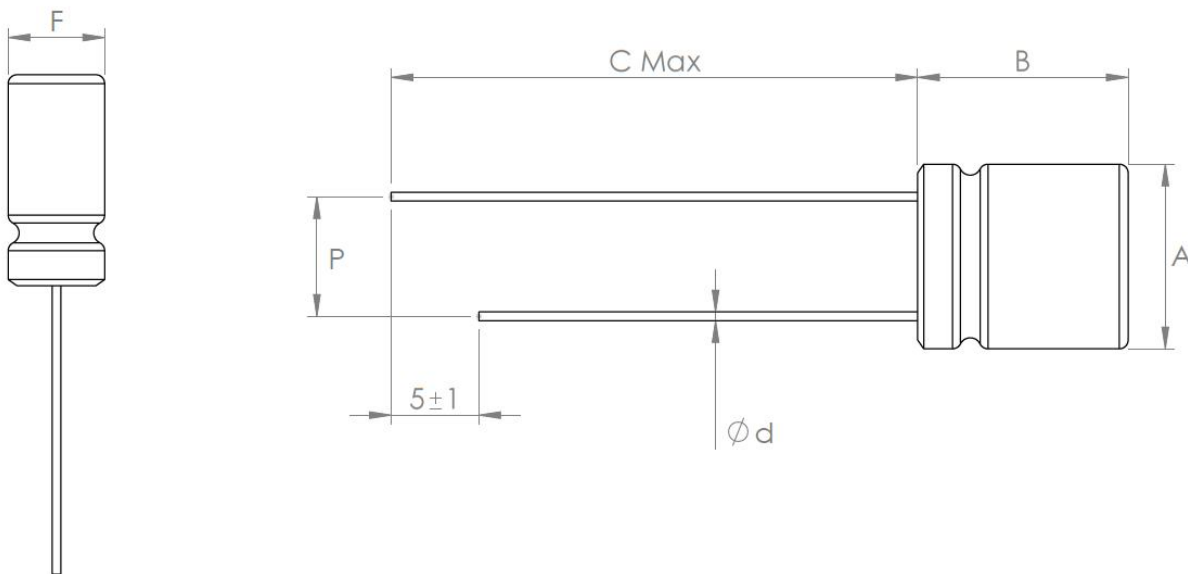

ABRACON PART#	SIZE (A x F x B) ±1	Pin Spacing P	Pin Length C (MAX)	Pin Diameter Ød
ADCM-S06R0SA104PB	10.5 x 5.5 x 12	6.8 ±0.5	30	0.5 ±0.05
ADCM-S06R0SA474WB	18.1 x 9.6 x 18	11.5 ±0.5	30	0.6 ±0.1
ADCM-S06R0SA105RB	16.5 x 8.5 x 22	12.0 ±0.5	30	0.6 ±0.1
ADCM-S06R0SA155RB	16.5 x 8.5 x 22	12.0 ±0.5	30	0.6 ±0.1
ADCM-S06R0SA205RB	20.5 x 10.5 x 19	15.3 ±0.5	30	0.6 ±0.1
ADCM-S06R0SA505QB	20.5 x 10.5 x 27	15.3 ±0.5	30	0.6 ±0.1
ADCM-S06R0SA605RB	20.5 x 10.5 x 33.5	15.3 ±0.5	30	0.6 ±0.1
ADCM-S06R0SA106RB	25.5 x 13 x 36	17.8 ±0.5	30	0.6 ±0.1
ADCM-S06R0SA224XB	13.5 x 7.5 x 15	9.0 ±0.5	30	0.5 ±0.05
ADCM-S06R0SA334WB	16.5 x 8.5 x 15	12.0 ±0.5	30	0.6 ±0.1
ADCM-S06R0SA305RB	20.5 x 10.5 x 22	15.3 ±0.5	30	0.6 ±0.1
ADCM-S06R0SA126RB	32.5 x 16.5 x 28	24.0 ±0.5	30	0.8 ±0.05

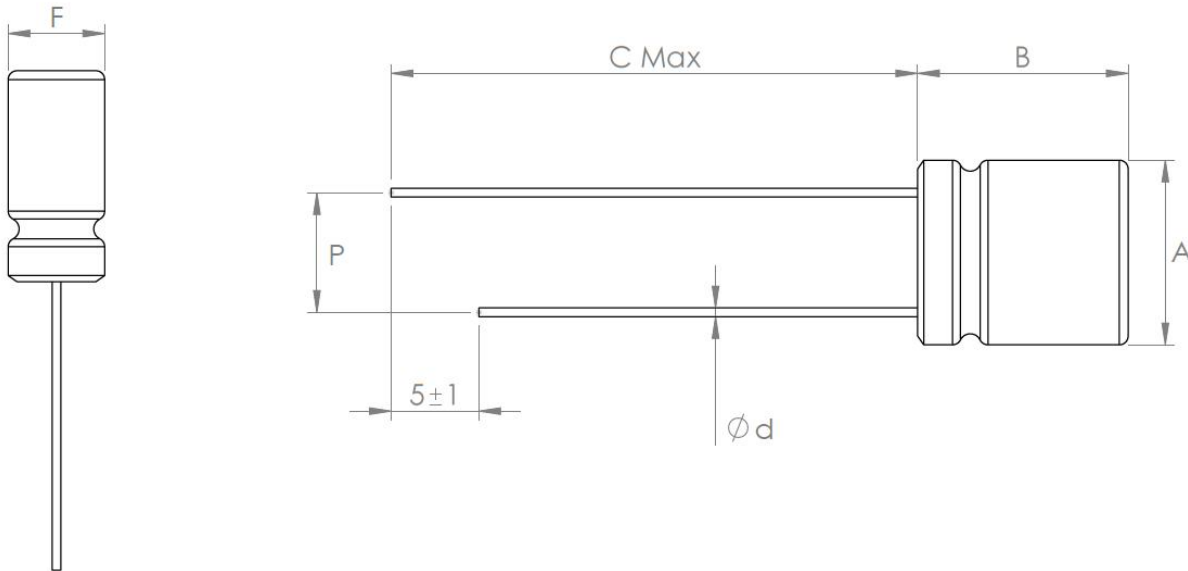
After Change:
Mechanical Specifications

ABRACON PART#	SIZE (A x F x B) ± 1	Pin Spacing P	Pin Length C (MAX)	Pin Diameter ϕd
ADCM-S06R0SA104PB	10.5 x 5.5 x 12	6.8 ± 0.5	30	0.5 ± 0.05
ADCM-S06R0SA474WB	16.5 x 8.5 x 15	12.0 ± 0.5	30	0.6 ± 0.1
ADCM-S06R0SA105RB	16.5 x 8.5 x 22	12.0 ± 0.5	30	0.6 ± 0.1
ADCM-S06R0SA155RB	16.5 x 8.5 x 22	12.0 ± 0.5	30	0.6 ± 0.1
ADCM-S06R0SA205RB	20.5 x 10.5 x 19	15.3 ± 0.5	30	0.6 ± 0.1
ADCM-S06R0SA505QB	20.5 x 10.5 x 27	15.3 ± 0.5	30	0.6 ± 0.1
ADCM-S06R0SA605RB	20.5 x 10.5 x 33.5	15.3 ± 0.5	30	0.6 ± 0.1
ADCM-S06R0SA106RB	25.5 x 13 x 36	17.8 ± 0.5	30	0.6 ± 0.1
ADCM-S06R0SA224XB	13.5 x 7.5 x 15	9.0 ± 0.5	30	0.5 ± 0.05
ADCM-S06R0SA334WB	16.5 x 8.5 x 15	12.0 ± 0.5	30	0.6 ± 0.1
ADCM-S06R0SA305RB	20.5 x 10.5 x 22	15.3 ± 0.5	30	0.6 ± 0.1
ADCM-S06R0SA126RB	32.5 x 16.5 x 28	24.0 ± 0.5	30	0.8 ± 0.05

Cause/Reason for Change:

Mechanicals dimensions have changed slightly to smaller A x F x B size. Pin pitch has increased by 0.5mm center-on-center.

Change Plan

Effective Date:

1/14/2026

Additional Remarks:
Change Declaration:

Changes described here do not affect the products function. Small changes to mechanical dimensions should be closely reviewed.

Issued Date:

1/14/2026

Issued By:

Gerald Capwell

Issued Department:

Engineering

Approval:

Gerald Capwell
Director, Engineering

Approval:

Reuben Quintanilla
Quality Director

Approval:

Ying Huang
Purchasing Director

For Abracon EOL only

Last Time Buy (if applicable):
Alternate Part Number / Part Series:
Additional Approval:
Additional Approval:
Additional Approval:

Customer Approval (If Applicable)

Qualification Status:

Approved Not accepted

Note: It is considered approved if there is no feedback from the customer 1 month after ECN/PCN is released.

Customer Part Number:
Customer Project:
Company Name:
Company Representative:
Representative Signature:
Customer Remarks: