

5mm PITCH
10mm PITCH

TAICOM

Vertical Mounting
Low Profile

TBV8xxAG (5mm)
TBV8xxBGN (10mm)

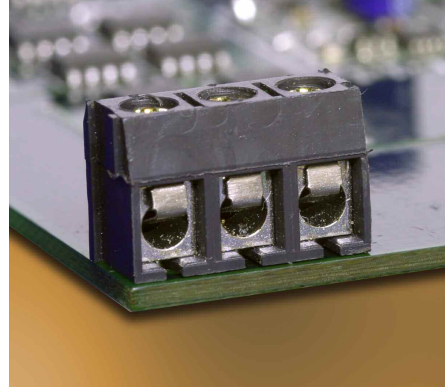

Dimensions (mm)

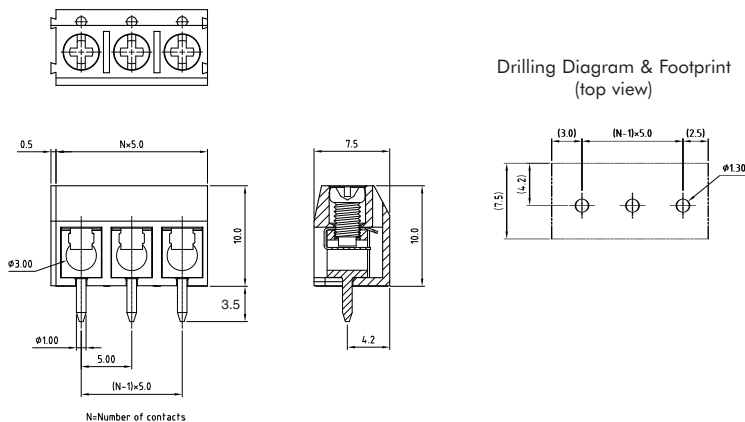

Ordering Information

Poles/ Ways	TAICOM Part No.	
	5mm	10mm
2	TBV802AG	TBV802BGN
3	TBV803AG	TBV803BGN
4	TBV804AG	TBV804BGN
5	TBV805AG	TBV805BGN
6	TBV806AG	TBV806BGN
7	TBV807AG	TBV807BGN
8	TBV808AG	TBV808BGN
9	TBV809AG	TBV809BGN
10	TBV810AG	TBV810BGN
11	TBV811AG	TBV811BGN
12	TBV812AG	TBV812BGN

N.B. Part numbers shown are for combi screws.
For slotted screws add -1 to the end of the part number.

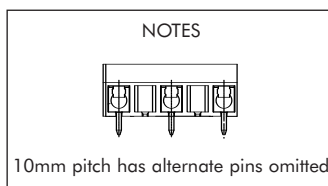

Specification

Materials	
Body mouldings	Black (RAL9011) Polyamide
Terminal inserts/pins	Brass, tin plated
Screws	Steel, zinc plated
Wire guards	Stainless steel

Ratings (limited by pcb)	
Current rating	15A/16A
Voltage rating	300Vac/250Vac
Test voltage	1.6kVac/1.5kVac
Insulation resistance	20MΩ max
Operating temperature range	-30°C to +105°C
Soldering temperature	250°C ± 10°C/5 sec

Mechanical Data	
Wire size	14-22 awg
Wire stripped length	6-7mm
Screw torque	2.6lb-in/4kgf-cm - 0.4Nm
Screw	M2.6 combi

Approvals	
UL and CSA	

For details of terminal blocks with alternative mounting orientations

Horizontal
refer to pages 10, 11 & 12

45° Angle
refer to page 14

Single Plane
refer to pages 15 & 16

Low profile terminal blocks with stainless steel wire guards. Choice of 5mm pitch or wider spaced 10mm pitch.

KEY FEATURES/BENEFITS

- ◆ Low profile
- ◆ 16A rating
- ◆ Holes provided for test probes
- ◆ Solid block to maintain pitch integrity over longer lengths
- ◆ Double dovetail interlocking
- ◆ Combi screws as standard
- ◆ UL94V-0 flame retardant bodies
- ◆ Spring action wire guards permit wire re-insertion
- ◆ 10mm pitch offers improved isolation between terminals

Options Available

Marked blocks -
A variety of markings and logos can be added to your requirements.

Screws -
Conventional slotted screws can be fitted in place of combi screws.

Body colours -
Other colours such as blue and green are available.

Longer Blocks -
Up to 24 ways can be supplied in 5mm pitch and up to 12 ways in 10mm pitch.

N.B. These options may be subject to minimum order quantities. Please contact our Sales Desk for further details.

WIRE GUARD