

5mm PITCH  
10mm PITCH

TAICOM

Horizontal  
Mounting

TBH2xxAGN (5mm)  
TBH2xxBGN (10mm)

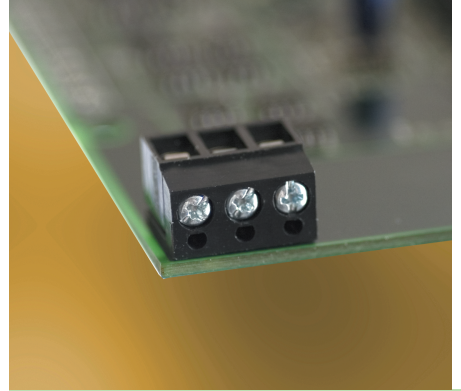

### Dimensions (mm)

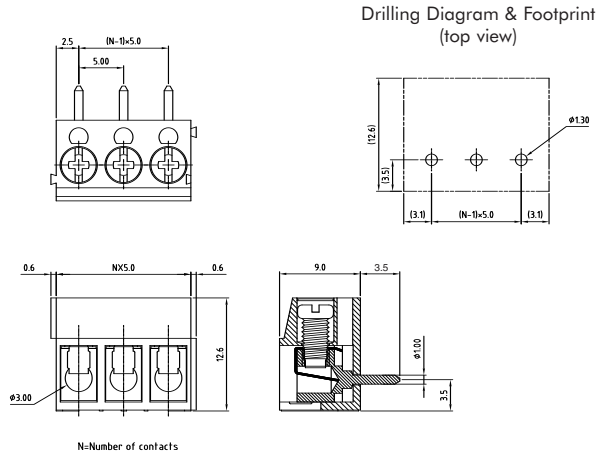

### Ordering Information

Poles/ Ways	TAICOM Part No.	
	5mm	10mm
2	TBH202AGN	TBH202BGN
3	TBH203AGN	TBH203BGN
4	TBH204AGN	TBH204BGN
5	TBH205AGN	TBH205BGN
6	TBH206AGN	TBH206BGN
7	TBH207AGN	TBH207BGN
8	TBH208AGN	TBH208BGN
9	TBH209AGN	TBH209BGN
10	TBH210AGN	TBH210BGN
11	TBH211AGN	TBH211BGN
12	TBH212AGN	TBH212BGN

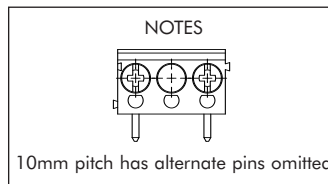

N.B. Part numbers shown are for combi screws.  
For slotted screws add -1 to the end of the part number.

### Specification

#### Materials

Body mouldings	Black (RAL9011) Polyamide
Terminal inserts/pins	Brass, tin plated
Screws	Steel, zinc plating
Wire guards	Stainless steel

#### Ratings (limited by pcb)

UL/CSA	UL/CSA
Current rating	16A/16A
Voltage rating	250Vac/250Vac
Test voltage	1.5kVac/1.5kVac
Insulation resistance	20MΩ max
Operating temperature range	-30°C to +105°C
Soldering temperature	250°C ±10°C/5 sec

#### Mechanical Data

Wire size	14-22 awg
Wire stripped length	6-7mm
Screw torque	2.6lb-in/4kgf-cm - 0.3Nm
Screw	M3 combi

#### Approvals

UL and CSA



For details of terminal blocks with alternative mounting orientations

**Vertical**  
refer to pages 2, 3 & 4

**45° Angle**  
refer to page 14

**Single Plane**  
refer to pages 15 & 16

Terminal blocks with stainless steel wire guards. Choice of 5mm pitch or wider spaced 10mm pitch.

WIRE GUARD

### KEY FEATURES/BENEFITS

- ◆ 16A rating
- ◆ Holes provided for test probes
- ◆ Double dovetail interlocking
- ◆ Combi screws as standard
- ◆ UL94V-0 flame retardant bodies
- ◆ 10mm pitch offers improved isolation between terminals

### Options Available

#### Marked Blocks -

A variety of markings and logos can be added to your requirements.

#### Screws -

Conventional slotted screws can be fitted in place of combi screws.

#### Body Colours -

Other colours such as green, blue and grey are available.

#### Longer Blocks -

Up to 24 ways can be supplied in 5mm pitch and up to 12 ways in 10mm pitch.

N.B. These options may be subject to minimum order quantities. Please contact our Sales Desk for further details.