

5mm PITCH  
10mm PITCH

TAICOM

Horizontal  
Mounting

TBH1xxAGN (5mm)  
TBH1xxBGN (10mm)

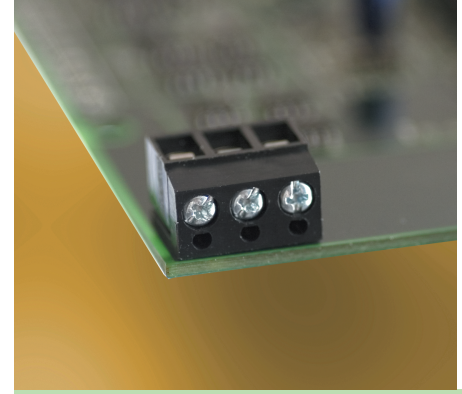

Dimensions (mm)

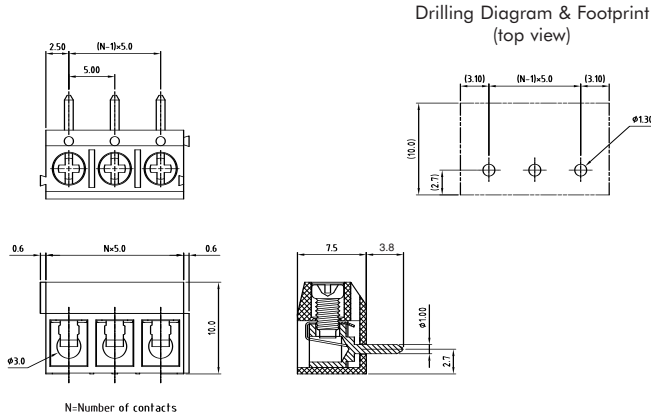

Ordering Information

Poles/ Ways	TAICOM Part No.	
	5mm	10mm
2	TBH102AGN	TBH102BGN
3	TBH103AGN	TBH103BGN
4	TBH104AGN	TBH104BGN
5	TBH105AGN	TBH105BGN
6	TBH106AGN	TBH106BGN
7	TBH107AGN	TBH107BGN
8	TBH108AGN	TBH108BGN
9	TBH109AGN	TBH109BGN
10	TBH110AGN	TBH110BGN
11	TBH111AGN	TBH111BGN
12	TBH112AGN	TBH112BGN

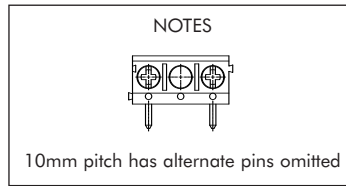

N.B. Part numbers shown are for combi screws.  
For slotted screws add -1 to the end of the part number.

Specification

Materials	
Body mouldings	Black (RAL9011) Polyamide
Terminal inserts/pins	Brass, tin plated
Screws	Steel, zinc plated
Wire guards	Stainless steel

Ratings (limited by pcb)	
Current rating	16A
Voltage rating	250Vac
Test voltage	1.5kVac
Insulation resistance	20MΩ max
Operating temperature range	-30°C to +105°C
Soldering temperature	250°C ±10°C/5 sec

Mechanical Data	
Wire size	16-22 awg
Wire stripped length	5-6mm
Screw torque	2.6lb-In/3.5lb-In - 0.4Nm
Screw	M2.6 combi

Approvals

cULus and CSA



For details of terminal blocks with alternative mounting orientations

**Vertical**  
refer to pages 2, 3 & 4

**45° Angle**  
refer to page 14

**Single Plane**  
refer to pages 15 & 16

Terminal blocks with stainless steel wire guards. Choice of 5mm pitch or wider spaced 10mm pitch.

WIRE GUARD

KEY FEATURES/BENEFITS

- ◆ 16A rating
- ◆ Hole provided for test probes
- ◆ Double dovetail interlocking
- ◆ Combi screws as standard
- ◆ UL94V-0 flame retardant bodies
- ◆ Spring action wire guards permit wire re-insertion
- ◆ 10mm pitch offers improved isolation between terminals

Options Available

Marked Blocks -

A variety of markings and logos can be added to your requirements.

Screws -

Conventional slotted screws can be fitted in place of combi screws.

Body Colours -

Other colours such as green, blue and grey are available.

Longer Blocks -

Up to 24 ways can be supplied in 5mm pitch and up to 12 ways in 10mm pitch.

N.B. These options may be subject to minimum order quantities. Please contact our Sales Desk for further details.