

BOURNS type EAW

ACE™

Through the use of combinatorial mathematics, the gray-code pattern of the Absolute Contacting Encoder (ACE™) is placed on a single track for a very economical, energy-efficient and compact product. The device also provides an absolute digital output that will retain its last position in the event of power failure. An intelligent alternative to incremental encoders and potentiometers, the ACE™ is ideally suited for many industrial, automotive, medical and consumer product applications.

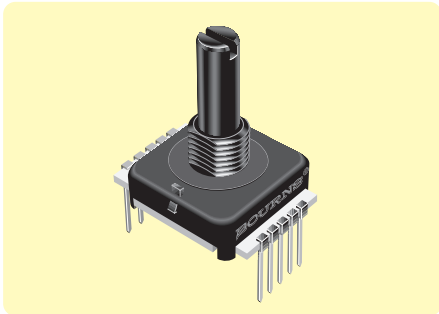

- ◆ Absolute encoder/gray code output
- ◆ Digital output
- ◆ Sturdy construction
- ◆ Bush or pcb mounted
- ◆ Slotted 6.35mm (1/4 in) shaft



Specification

Electrical Characteristics

Resolution range	8-bit gray code with 128 absolute states
Closed circuit resistance	5Ω max.
Open circuit resistance	100kΩ min.
Contact rating	10mA at 10Vdc or 0.1W max.
Insulation resistance	1,000MΩ at 500Vdc min.
Dielectric withstand voltage	MIL-STD-202 method 301
	1,000Vac min.
Electrical travel	Continuous
Contact bounce	2.7ms max. at 60rpm
Operating rpm	120 max.

Environmental Characteristics

Temperature range	
storage	-40°C to +85°C
operating	+1°C to +85°C
Humidity	MIL-STD-202, method 103B, condition B
Vibration	15G
contact bounce	0.1ms max.
Shock	50G
contact bounce	0.1ms max.

Mechanical Characteristics

Operating torque	0.52 to 1.75Ncm
Mechanical rotation	Continuous
Rotational life	50,000 shaft revolutions min.
Static shaft side load	44.5N

Manf. Part No. & anglia Order Code
EAW0J-B24-AE0128

Dimensions (mm)

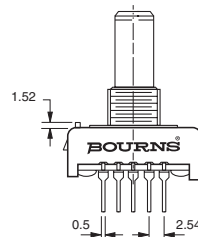
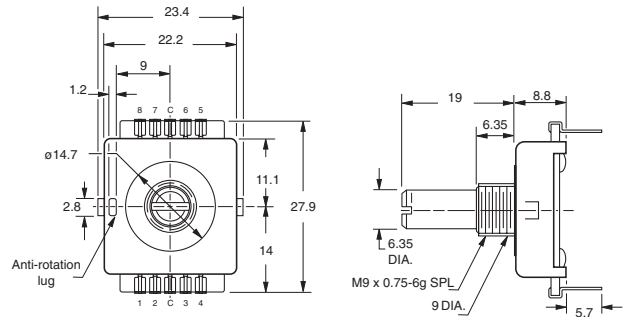

Mounting Holes

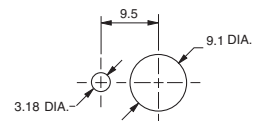

P.C.B. Layout

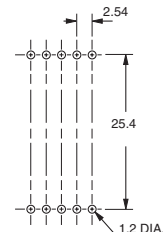

For the very latest information and news on the full range of BOURNS products available from Anglia, visit our website :
www.anglia.com/bourns

Alternatively, contact our Sales Desk to discuss your specific requirements.

● **PCB brackets and other shaft styles available**

Please contact our Sales Desk for details

BOURNS type EAW *continued*

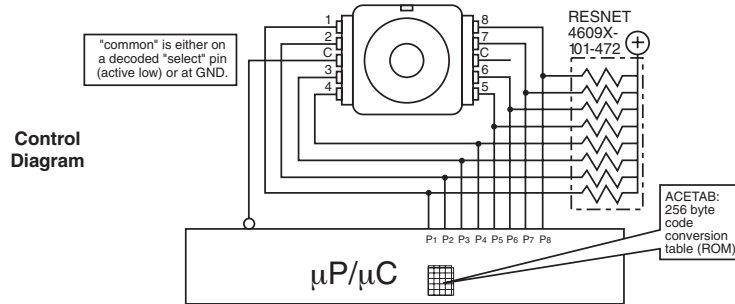

Pin Output Code

Position	P8	P7	P6	P5	P4	P3	P2	P1	Decimal Output
0	0	1	1	1	1	1	1	1	127
1	0	0	1	1	1	1	1	1	63
2	0	0	1	1	1	1	1	0	62
3	0	0	1	1	1	0	1	0	58
4	0	0	1	1	1	0	0	0	56
5	1	0	1	1	1	0	0	0	184
6	1	0	0	1	1	0	0	0	152
7	0	0	0	1	1	0	0	0	24
8	0	0	0	0	1	0	0	0	8
9	0	1	0	0	1	0	0	0	72
10	0	1	0	0	1	0	0	1	73
11	0	1	0	0	1	1	0	1	77
12	0	1	0	0	1	1	1	1	79
13	0	0	0	0	1	1	1	1	15
14	0	0	1	0	1	1	1	1	47
15	1	0	1	0	1	1	1	1	175
16	1	0	1	1	1	1	1	1	191
17	1	0	0	1	1	1	1	1	159
18	0	0	0	1	1	1	1	1	31
19	0	0	0	1	1	1	0	1	29
20	0	0	0	1	1	1	0	0	28
21	0	1	0	1	1	1	0	0	92
22	0	1	0	0	1	1	0	0	76
23	0	0	0	0	1	1	0	0	12
24	0	0	0	0	0	1	0	0	4
25	0	0	1	0	0	1	0	0	36
26	1	0	1	0	0	1	0	0	164
27	1	0	1	0	0	1	1	0	166
28	1	0	1	0	0	1	1	1	167
29	1	0	0	0	0	1	1	1	135
30	1	0	0	1	0	1	1	1	151
31	1	1	0	1	0	1	1	1	215
32	1	1	0	1	1	1	1	1	223
33	1	1	0	0	1	1	1	1	207
34	1	0	0	0	1	1	1	1	143
35	1	0	0	0	1	1	1	0	142
36	0	0	0	0	1	1	1	0	14
37	0	0	1	0	1	1	1	0	46
38	0	0	1	0	0	1	1	0	38
39	0	0	0	0	0	1	1	0	6
40	0	0	0	0	0	0	1	0	2
41	0	0	0	1	0	0	1	0	18
42	0	1	0	1	0	0	1	0	82
43	0	1	0	1	0	0	1	1	83
44	1	1	0	1	0	0	1	1	211
45	1	1	0	0	0	0	1	1	195
46	1	1	0	0	1	0	1	1	203
47	1	1	1	0	1	0	1	1	235
48	1	1	1	0	1	1	1	1	239
49	1	1	1	0	0	1	1	1	231
50	1	1	0	0	0	1	1	1	199
51	0	1	0	0	0	1	1	1	71
52	0	0	0	0	0	1	1	1	7
53	0	0	0	1	0	1	1	1	23
54	0	0	0	1	0	0	1	1	19
55	0	0	0	0	0	0	1	1	3
56	0	0	0	0	0	0	0	1	1
57	0	0	0	0	1	0	0	1	9
58	0	0	1	0	1	0	0	1	41
59	1	0	1	0	1	0	0	1	169
60	1	1	1	0	1	0	0	1	233
61	1	1	1	0	0	0	0	1	225
62	1	1	1	0	0	1	0	1	229
63	1	1	1	1	0	1	0	1	245

Position	P8	P7	P6	P5	P4	P3	P2	P1	Decimal Output
64	1	1	1	1	0	1	1	1	247
65	1	1	1	1	0	0	1	1	243
66	1	1	1	1	0	0	0	1	227
67	1	0	1	0	0	0	1	1	163
68	1	0	0	0	0	0	1	1	131
69	1	0	0	0	1	0	1	1	139
70	1	0	0	0	1	0	0	1	137
71	1	0	0	0	0	0	0	1	129
72	1	0	0	0	0	0	0	0	128
73	1	0	0	0	0	1	0	0	132
74	1	0	0	1	0	1	0	0	148
75	1	1	0	1	0	1	0	0	212
76	1	1	1	1	1	0	1	0	244
77	1	1	1	1	1	0	0	0	240
78	1	1	1	1	0	0	1	0	242
79	1	1	1	1	1	1	0	1	250
80	1	1	1	1	1	0	1	1	251
81	1	1	1	1	1	0	0	1	249
82	1	1	1	1	1	0	0	0	241
83	1	1	0	1	0	0	0	1	209
84	1	1	0	0	0	0	0	1	193
85	1	1	0	0	0	1	0	1	197
86	1	1	0	0	0	1	0	0	196
87	1	1	0	0	0	0	0	0	192
88	0	1	0	0	0	0	0	0	64
89	0	1	0	0	0	0	1	0	66
90	0	1	0	0	1	0	1	0	74
91	0	1	1	0	1	0	1	0	106
92	0	1	1	1	1	0	1	0	122
93	0	1	1	1	1	0	0	0	120
94	0	1	1	1	1	0	0	1	121
95	0	1	1	1	1	1	0	1	125
96	1	1	1	1	1	1	0	1	253
97	1	1	1	1	1	1	0	0	252
98	1	1	1	1	1	0	0	0	248
99	1	1	1	0	1	0	0	0	232
100	1	1	1	0	0	0	0	0	224
101	1	1	1	0	0	0	1	0	226
102	0	1	1	0	0	0	1	0	98
103	0	1	1	0	0	0	0	0	96
104	0	0	1	0	0	0	0	0	32
105	0	0	1	0	0	0	0	1	33
106	0	0	1	0	0	1	0	1	37
107	0	0	1	1	0	1	0	1	53
108	0	0	1	1	1	1	0	1	61
109	0	0	1	1	1	1	0	0	60
110	1	0	1	1	1	1	0	0	188
111	1	0	1	1	1	1	1	0	190
112	1	1	1	1	1	1	1	0	254
113	0	1	1	1	1	1	1	0	126
114	0	1	1	1	1	1	0	0	124
115	0	1	1	1	0	1	0	0	116
116	0	1	1	1	0	0	0	0	112
117	0	1	1	1	0	0	0	1	113
118	0	0	1	1	0	0	0	1	49
119	0	0	1	1	0	0	0	0	48
120	0	0	0	1	0	0	0	0	16
121	1	0	0	1	0	0	0	0	144
122	1	0	0	1	0	0	1	0	146
123	1	0	0	1	1	0	1	0	154
124	1	0	0	1	1	1	1	0	158
125	0	0	0	1	1	1	1	0	30
126	0	1	0	1	1	1	1	0	94
127	0	1	0	1	1	1	1	1	95